



Mits Air™ Through the Wall Heat Pump

**Plug & Play Solution for Heating, Air
Conditioning & Fresh Air Intake**



- ✓ For residential or commercial application
- ✓ No need for an outdoor unit
- ✓ 2 KW of electric back-up heat
- ✓ Discreet & elegant installation
- ✓ Low noise, low maintenance

CONTACT YOUR LOCAL DEALER TODAY

Technical Data:

V/Ph/Hz: 208-230/1/60

Cooling Capacity: 9,900 Btu/h

Heating Capacity: 10,000 Btu/h

Connects with 208/230v 15A

LCDI Plug

www.mitsair.com

DIMENSIONS

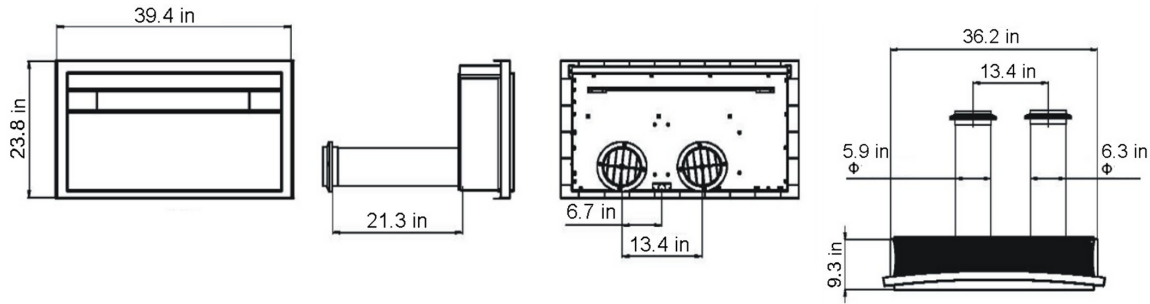

Note: The external pipes have two different diameters, use 6.3 in for inlet side and 5.9 in for outlet side.

TECHNICAL DATA

AIRFLOW		H		265
		M	ft ³ /min	235
		L		205
COOLING CAPACITY	*		Btu/h	9,900
HEATING CAPACITY	**		Btu/h	10,000
ELECTRIC HEATER CAPACITY			Btu/h	6,800
EER			Btu/W	11.18
COP			Btu/Btu	3.53
NOISE LEVEL @ 3.28 FT	INDOOR	H	dB/A	48.2
		M		46.0
		L		43.7
	OUTDOOR ***	H	dB/A	58.1 (54.6***)
		M		-
		L		46.6 (43.1***)
ELECTRICAL INSULATION PROTECTION CLASS				I
WATER PROOF CLASS				IPX4
DEHUMIDIFICATION			gal/h	0.217
POWER SUPPLY			V/Ph/Hz	208-230/1/60
POWER INPUT	COOLING		W	885
	HEATING		W	830
RUNNING CURRENT	COOLING		A	4.5
	HEATING		A	4.1
START CURRENT	COOLING		A	12.3
	HEATING		A	11.6
ELECTRIC HEATER RUNNING CURRENT			A	9.1
COMPRESSOR				ROTARY
REFRIGERANT CONTROL				CAPILLARY
REFRIGERANT CHARGE			lb	1.43
REFRIGERANT TYPE				R410A
DIMENSIONS	WIDTH		in	43.11
	HEIGHT			22.83
	DEPTH			9.65
GROSS WEIGHT			lb	114.64

WARRANTY: 3 years compressor, 1 year parts.
All warranty is active from date of installation.
Labour Warranty is the responsibility of the
Installing Contractor.

*To register warranty on equipment, go to
www.mitsair.com/warranty-registration

All testing and values are per Manufacturer's testing.

All capacities are based on:

*Cooling: Indoor 80.6°F DB, 66.2°F WB, outdoor
95°F DB, 75.2°F WB.

**Heating: Indoor 68°F DB, outdoor 44.6°F DB,
42.8°F WB.

***Values in parentheses refer to outdoor sound
pressure levels with optional sound attenuation
device installed.

Distributed By:



Head Office:
Mississauga

1608 Bonhill Road
Mississauga, ON
L5T 1C7
1 (800) 567-2221
info@mitsair.com

**Hydronics &
Unico Division**

6125 Netherhart Road
Mississauga, ON
L5T 1G5
1 (905) 362-5293
hydronics@mitsair.com

Barrie Branch

691 Dunlop Street West
Barrie, ON
L4N 9W9
1 (800) 688-1673
barrie@mitsair.com

London Branch

90 Towerline Place
London, ON
N6E 2T1
1 (519) 914-9000
london@mitsair.com

Windsor Branch

11629 County Road 42
Tecumseh, ON
N8N 0H1
1 (519) 914-0332
windsor@mitsair.com

www.mitsair.com