

diamondAIR

# Installation and Operation Manual

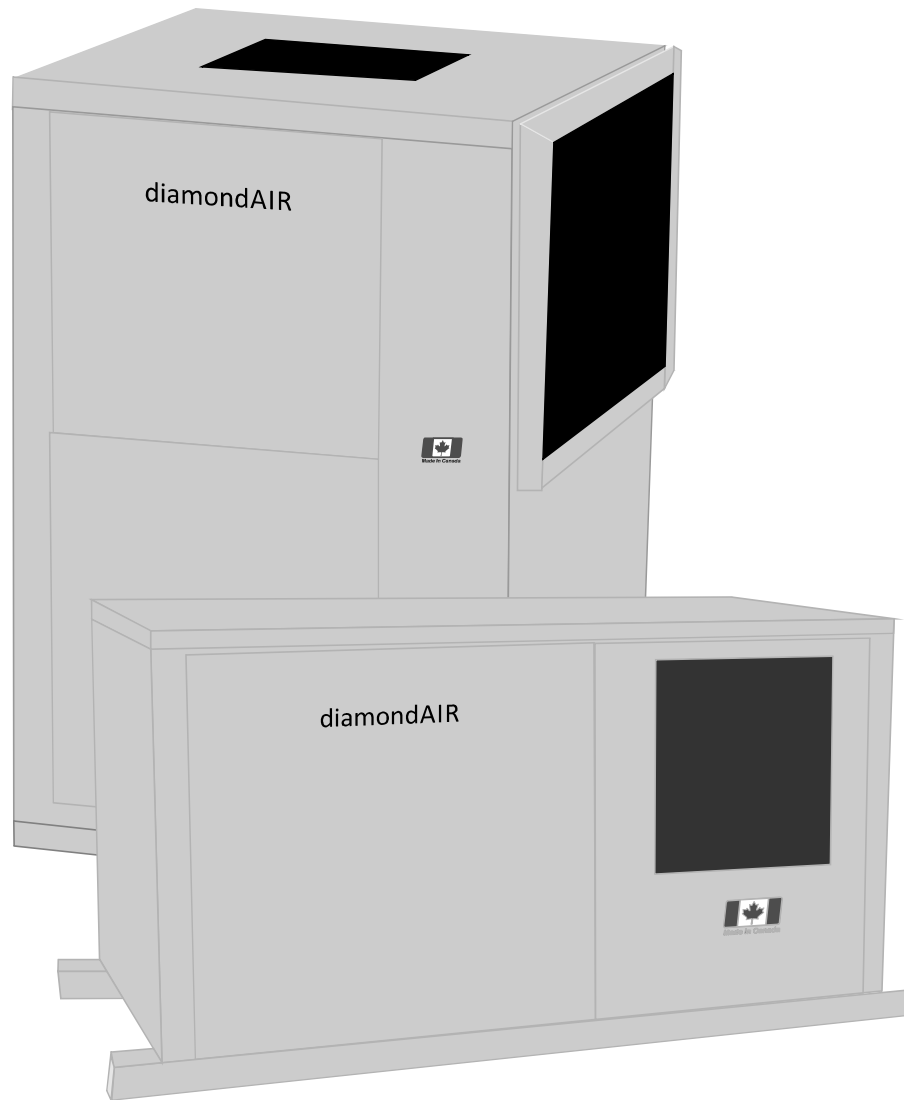

**LHA & LVA Series**  
Central Ducted  
Vertical & Horizontal  
Air Conditioners

# Maintenance & Operation

## **WARNING**

**This procedure is intended for qualified service personnel. To prevent injury or death due to electrical shock hazard or by contact with moving parts, power must be electrically disconnected from the equipment.**

### **1. Corrosive Atmosphere:**

Standard equipment is not designed to operate in atmospheres containing chlorine, fluorine, solvents or other chemicals, Under no circumstances should it be used in any atmosphere containing explosive or flammable vapours.

### **2. Filters:**

The air filters on this equipment need periodic and regular inspection / maintenance. If there is a visible deposit of dust and debris, they require cleaning or replacement depending on the type of filter that was used during the installation. Your installing contractor can advise you what type was used. Frequency of inspection should be a minimum of every three months, but may require more frequent inspection in installations that have high amounts of dust and debris in the air. Failure to maintain your filters can result in loss of performance and cause expensive repairs not covered by the warranty.

### **3. Fan Motor**

The fan motor requires oil annually with an SAE 20 non-detergent oil. Plastic caps on the end bell of the motor must be removed and twenty drops of oil added. Failure to oil the motor may result in its seizing up and over oiling can cause secondary bearing damage or a buildup of lint and debris that can adversely affect the operation of the motor and fan. You must disconnect the power before servicing or inspecting the fan motor or fan assembly or- severe physical harm to the servicer can occur.

### **4. General Inspection:**

Power must be disconnected to the equipment before performing the general inspection to prevent mechanical or electrical harm to the servicer. Carefully inspect the evaporator coil surface to ensure that no debris or linting has occurred. Examine refrigerant connections, tubing and attachments for leaks. Examine electrical connections for browning / charring that indicates loose connections and eminent failure. Examine the contactor for pitting. Examine the blower wheel for dirt deposits and debris. Check the blower motor for excess bearing wear or seizing. Check connecting water hoses / tubing for leaks and cracking and where strainers have been installed that they are not clogged or reduced by scale or debris. Check the condensate pan for scale build-up or other substances that may impair or block draining. Ensure that the drain works correctly and if a pump is used that it is inspected and serviced according to its manufacturer's instructions. Repair or maintain as required.

### **5. Water Quality / Heat Exchanger**

The equipment transfers heat from the conditioned air to the water flow through the heat exchanger. It is therefore imperative that a supply of water is unimpaired to the machine. Strainers should be installed in the hoses or tubing supplying the water to the machine, and these may collect scale or debris and prevent it from lodging in the heat exchanger or water regulating valve. Water quality directly affects the efficiency of the transfer of heat, and must always be considered. Sufficient water pressure must be available to the machine together with adequate flow, or equipment malfunction will result. Scaling of the heat exchanger is not warranted and will reduce the equipment efficiency and may cause loss of use by tripping the high pressure lock out circuit.

## **WARNING**

**When replacing parts on this equipment, use only the specified diamondAIR part. Substitution may result in an inoperative safety circuit and may cause a hazardous condition**

# Trouble Shooting

This chart is provided as a guide only and is not a definitive work. Trouble shooting and repairs are intended to be carried out only by trained and qualified personnel. Disconnect power before servicing to prevent electrical or mechanical injury or death.

Symptom	Cause	Check:
Fan and compressor will not operate.	1. Power off	1. Check main fuses and disconnect.
	2.(a) Improperly wired	2. Check voltage, wiring and terminations
	(b) Loose connections	
	3. 24v. supply	3. Check thermostat & wiring
	4. Thermostat	4. Ensure thermostat is turned on. Replace if faulty.
5. Firestat/Freezestat	5. Determine cause of trip.	
Fan operates, compressor will not start.	1. Thermostat incorrectly set.	1. Adjust thermostat
	2. Thermostat defective	2. Replace faulty thermostat.
	3. Safety lock-out tripped	3. Determine cause of safety lockout and repair cause.
Compressor hums, doesn't start.	1. Low or wrong voltage	1. Determine actual voltage and phase, compare to nameplate.
	2. Capacitor problem	2, Test capacitor(s).
	3. Water quality problem	3. Determine water quality, pressure differential and determine flow rate.
Fan starts but cuts out	1. Faulty fan relay	1. Check fan relay for browning.
	2. Incorrect or low voltage.	2. Check actual voltage and compare to rating plate.
	3. Faulty capacitor	3. Test capacitor.
	4. Doesn't turn freely	4. Oil fan motor.
	5. Seized	5. Replace fan motor.
	6. High internal amperage	6. Change to lower fan speed.
High suction pressure	1. Inadequate water supply	1. Confirm water quality, pressure differential and water flow rate.
	2. Excessive load	2. Estimate area load and compare to nameplate.
	3. High latent load	3. Perform DQ calculation and compare to engineer's specification.
	4. Water inlet and outlet lines reversed.	4. Check hoses and reverse if necessary.
High discharge pressure	1. Improper water regulating valve setting	1. Adjust water regulating valve to standard pressure setting.
	2. Inadequate water quality	2. Determine that stop cocks are fully open, strainers are clear and unobstructed, determine if there is sufficient pressure differential, adequate inlet temperature and full flow of water. Check water quality and determine if scaling has occurred.
	3. Inlet and outlet hoses reversed.	3. Reverse hoses if necessary.

**If you require diagnostic assistance, complete the form on page 6 and fax to your local diamondAIR distributor, together with a covering sheet clearly indicating the problem, symptoms and observations made**

# INSTALLATION

## CAUTION

**This installation section is not a definitive work and is intended as a guide to trained and qualified personnel who are licensed as required. Installation must be done in a workmanlike manner and must comply with all applicable laws, regulations, codes and bylaws. Improper installation can result in property damage, injury or death.**

### 1. Inspection

Carefully uncrate the equipment. Ensure that the rated voltage on the nameplate matches the requirement for the installation. If there is hidden damage to the machine, a claim must be made to your carrier within fifteen days of the receipt of the machine. Hidden damage is not the responsibility of diamondAIR or your distributor. It is the responsibility of the purchaser to file all necessary documents with their carrier.

### 2. Pre-Installation:

Maintenance, operation and installation instructions are shipped with each diamondAIR unit together with an equipment installation registration card. Read all instructions and familiarize yourself with the instructions / procedures. Ensure that all electrical terminals are clean and tight, and that any shipping supports in the fan are removed. If the blower is to be repositioned to side discharge, exchange the panels and reroute wires if necessary. If the unit is to be used for high sensible operation, change the fan wire connection from medium to high speed (or adjust fan pulley on belt drive). Protect the cabinet from damage during installation prior to start-up.

### 3. Location:

Consideration must be given to location. The machine must be mounted in an area with adequate clearance and access for servicing. Consideration must also be given to vibration that is a normal expectation of operation to ensure that it will not be objectionable to Occupants of the space. Locate the unit outside a space where objections may occur. Lowest sound levels from ductwork can be obtained installing at least one 90° elbow prior to air outlets and ducted return air. All duct should be internally insulated. If the machine is installed in a closet or sealed ceiling, there must be adequate provision for service. Installation at the equipment of flexible connection collars will preclude vibration transmission to the ductwork. If a fire wall is breached by ductwork or other openings, a fire damper or other means acceptable to the inspecting authority must be used.

### 4. Atmosphere:

Standard units are not designed for installation in corrosive atmospheres or where solvents or flammables are present. If

these are present, contact your diamondAIR distributor for suitability of the equipment for the application.

### 5. Operating Temperatures:

The system is rated for the following temperatures on water systems:

Water Entering Temperatures		
MODE	MINIMUM	MAXIMUM
Cooling	45°F	110°F
Heating	55°F	85°F

### 6. Water System:

Ensure that the water system has sufficient capacity to provide the necessary flow for the equipment's operation. Correctly identify the water supply / water return stop-cocks, and purge water from the branch to eliminate debris. Install strainer washers to the inlet of the supply hose. Inspect the hoses to ensure that they are mechanically fit and will not fail, and that the length is adequate and will not cause complications. On balanced-flow tower systems, remove the water regulating valve from the air conditioner / heat pumps and install the factory fabricated bypass. Ensure that the ph of the water and precipitants in the water system will not cause scaling or fouling of the heat exchanger. If problems are suspected, consult experts and give consideration to their recommendations.

### 7. Suspending the Equipment:

It is important that the equipment is safely and securely suspended to prevent injury or death. Consult with local officials and your diamondAIR distributor for acceptable methods for your area. In seismic areas, a special certified suspension system is required. If jam nuts are being used, ensure that they are properly torqued to prevent support failure.

# INSTALLATION

## **8. Condensate Drain:**

Ensure that the drain is properly trapped and test by pouring adequate quantities of water down it. Connection from the drain to the machine should be by flexible tubing to preclude transfer of vibration from the equipment to the plumbing. In the event of an accessory condensate pump being used, the tubing should be run to prevent it collapsing on itself and causing a premature pump failure. Some pumps require annual servicing of strainers and provision must be made for annual inspection of all pumps.

## **9. Electrical:**

All electrical work must be completed by qualified personnel and must comply with all applicable laws, codes, regulations and bylaws. A line-of-sight disconnect must be used to ensure easy electrical disconnection of the equipment, and the final connection to the equipment should be made with flexible metallic conduit. Ensure that the voltage is correct for the system by comparing it with the specified power required on the equipment nameplate, and that conductor size and type is acceptable with respect to voltage, current, wire length and other requirements.

Low voltage wiring installed in a common plenum must have a fire rating. If a digital interface or thermostat is used, the low voltage wire must be shielded and the shielding grounded at one end only. A low voltage “C” common connection is supplied for accessories. Current draw for accessories must not exceed fifteen watts at twenty-four volts a/c.

## **10. Alarm Contacts:**

The equipment is supplied with alarm capability if a safety lock-out occurs. Two “A” low voltage terminals are connected to a normally open contact rated for ten amps.

## **11. Firestat / Freezestat:**

Capability within the system is provided for firestat / freezestat integration. To install, remove the jumper from “FS” and “R”. Install the device across these terminals.

# WARNING

Do not use the equipment during construction to prevent construction debris and dirt from causing problems. **Damage arising from dirt, debris or scaling is not warrantable.**

## START-UP

1. Turn on all water supply stopcocks and ensure that there are no leaks.
2. Ensure that the condensate drain / pump is working correctly by pouring adequate water into the condensate pan. Check to ensure that the equipment is level or tilted slightly to the condensate drain.
3. With the line-of-sight disconnect open, check voltage & phase and compare to the nameplate. If correct, turn off thermostat and close disconnect. If the system is intended for use as a high sensible unit, check that the high speed of the fan is connected.
4. Ensure that all shipping straps / supports have been removed, the blower is free of obstructions, and that the filter /evaporator is clean and free of dirt / debris.
5. Ensure that filters are clean and that ductwork diffusers are open.
6. Turn on the line-of-sight disconnect. Turn on the fan from the thermostat. Turn on the cooling cycle.
7. Complete the start-up record on page 6.
8. Properly instruct end user or representative on system operation and deliver this booklet to them.

### Note:

When checking the refrigerant pressure, set the water regulating valve during operation to 225 PSIG for normal application, 210 PSIG for high sensible operation. If you cannot lower an abnormally high discharge pressure it is an indication of inadequate water supply. Suction pressure may vary according to the latent load in the space. If you believe there is an abnormal suction pressure, contact your local diamondAIR distributor.

If you have service questions or concerns, do not hesitate to contact your local diamondAIR distributor who will be glad to assist you. If you are unsure of who your local distributor is, call the number listed on the back page and we will help you contact them.

## diamondAIR Electrical Characteristics

Model	Voltage	Compressor		Blower Motor		Unit Total		Min. Circuit Ampacity	
		RLA	LRA	RLA	HP	FLA	RLA		
LVA/LHA12NSU0	208/230/-1-60	4.8	29	2.2	1/4	7	8.2	15	
LVA/LHA18NSU0	208/230/-1-60	5.5	48	2.2	1/4	7.7	10	15	
LVA/LHA24NSU0	208/230/-1-60	7.2	58.3	2.2	1/4	9.6	11.2	20	
LVA/LHA30NSU0	208/230/-1-60	9.3	72.5	2.2	1/4	11.5	14.2	25	
LVA/LHA36NSU0	208/230/-1-60	10.3	79	5	1/2	15.3	18	30	
LVA/LHA36TSU0	208/230/-3-60	7.6	73	5	1/2	12.6	14	20	
LVA/LHA36RSU0	460-3-60	SPECIFICAITONS ON REQUEST							
LVA/LHA36ZSU0	575/3/60	3.1	36.5	1.9	3/4	5	5.5	15	
LVA/LHA42NSU0	208/230/-1-60	13	105	5	1/2	18	20	40	
LVA/LHA42TSU0	208/230/-3-60	8.9	88	5	1/2	13.9	15	25	
LVA/LHA42RSU0	460/3/60	SPECIFICAITONS ON REQUEST							
LVA/LHA42ZSU0	575/3/60	3.7	34	1.9	3/4	5.6	6.5	15	
LVA/LHA48NSU0	208/230/-1-60	14	117	5.4	3/4	19.4	22.9	40	
LVA/LHA48TSU0	208/230/-3-60	9	83.1	5.4	3/4	14.4	16.7	25	
LVA/LHA48RSU0	460/3/60								
LVA/LHA48ZSU0	575/3/60	3.7	33	1.9	3/4	5.6	6.5	15	
LVA/LHA60NSU0	208/230/-1-60	18.3	158	5.4	3/4	23.7	28.3	50	
LVA/LHA60TSU0	208/230/-3-60	12.8	137	5.4	3/4	18.2	21.4	40	
LVA/LHA60RSU0	460/3/60	SPECIFICAITONS ON REQUEST							
LVA/LHA60ZSU0	575/3/60	5.1	50	1.9	3/4	7	8.3	15	
LVA90TSU0	208/230-3-60	9.0x2	83.1x2	5.6	1.5	23.6	30	40	
LVA90RSU0	460-3-60	SPECIFICAITONS ON REQUEST							
LVA90ZSU0	575-3-60	3.7x2	33x2	1.7	1.5	9.1	15	20	
LVA120TSU0	208/230-3-60	12.8x2	137x2	8.8	3	34.4	40	70	

Start-Up Data	
Model:	
Serial No.:	
Job Name:	
Job Address:	
Job Location:	
Voltage:	
Loop GPM:	
Loop Type:	
Fluid Type:	
Energy Mgmt. Syst.:	
EMS Address:	
Alarm Interface:	
Condensate Alarm:	

Temperatures (°F)			
Position	Location	Dry Bulb	Wet Bulb
1	Water Inlet		
2	Water Outlet		
3	Discharge		
4	Suction		
5	Air Entering		
6	Air Leaving		
7	Refrigerant Entering		
8	Refrigerant Leaving		

SERVICER INFORMATION:	
Technician's Name:	
Service Contractor:	
Telephone No.:	
Fax No.:	
Date of Start-Up:	
Date of Report:	

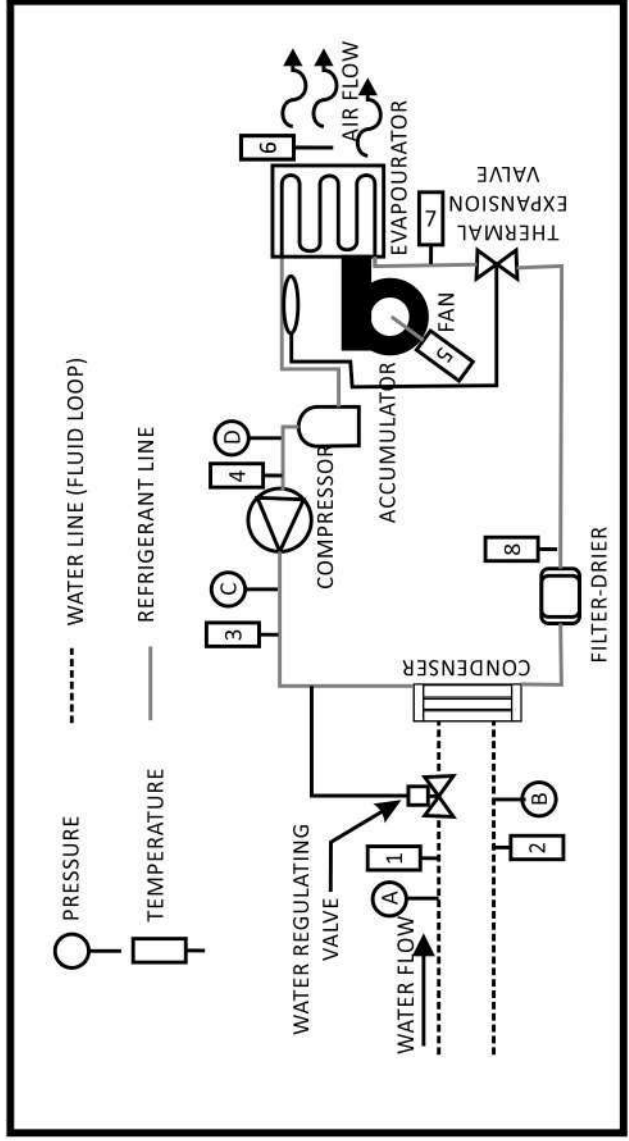

Comments:

PRESSURE RECORD (PSIG)	
A	Water Inlet
B	Water Outlet
C	Discharge
D	Suction

SYSTEM DATA	
Voltage and Phase:	
Total Amperage:	
Compressor Amperage:	
Fan Amperage:	
Air Filter Condition:	
Belt Tension:	
Blower Wheel Condition:	
Loop Flow Rate (GPM)	
Air Flow (CFM)	
System Air Flow (CFM)	
Air Inlet Pressure (in wc)	
Air Outlet Pressure (in wc)	

**diamondAIR**  
Start-UP / Diagnostic Report

# LHA - LVA 208-230/1/60

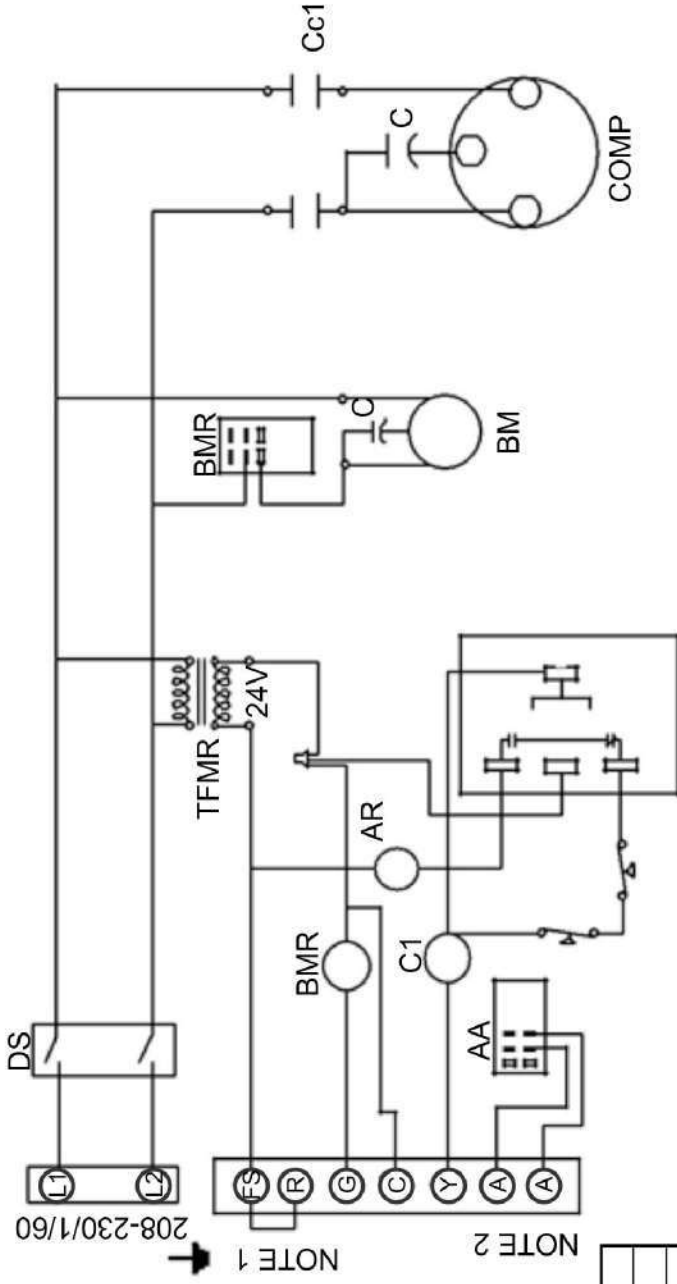

- Notes:**
- 1 Remove jumper and install wires from fire alarm system. Contacts should be normally closed.
  - 2 Alarm contacts are rated for 208/230 1 amp. Contact is normally open and closes on lock out from SSLO module.

LEGEND	
A	Alarm Contact
AR	Alarm Relay
BM	Blower Motor
BMR	Blower Motor Relay
BMRC	Blower Motor Relay Control
C	Capacitor
C1	Contact 1
CC1	Compressor Contactor 1
COMP	Compressor
DS	Disconnect Switch
FSR	Fire Stat Relay
FSRC	Fire Stat Relay Coil
HPC	High Pressure Control
LPS	Low Pressure Switch (Option)
SSLO1	Solid State Lock-Out 1
TFMR	Transformer

## diamondAIR



# LVA / LHA Single Compressor Systems

208-230/3/60      460/3/60      575/3/60

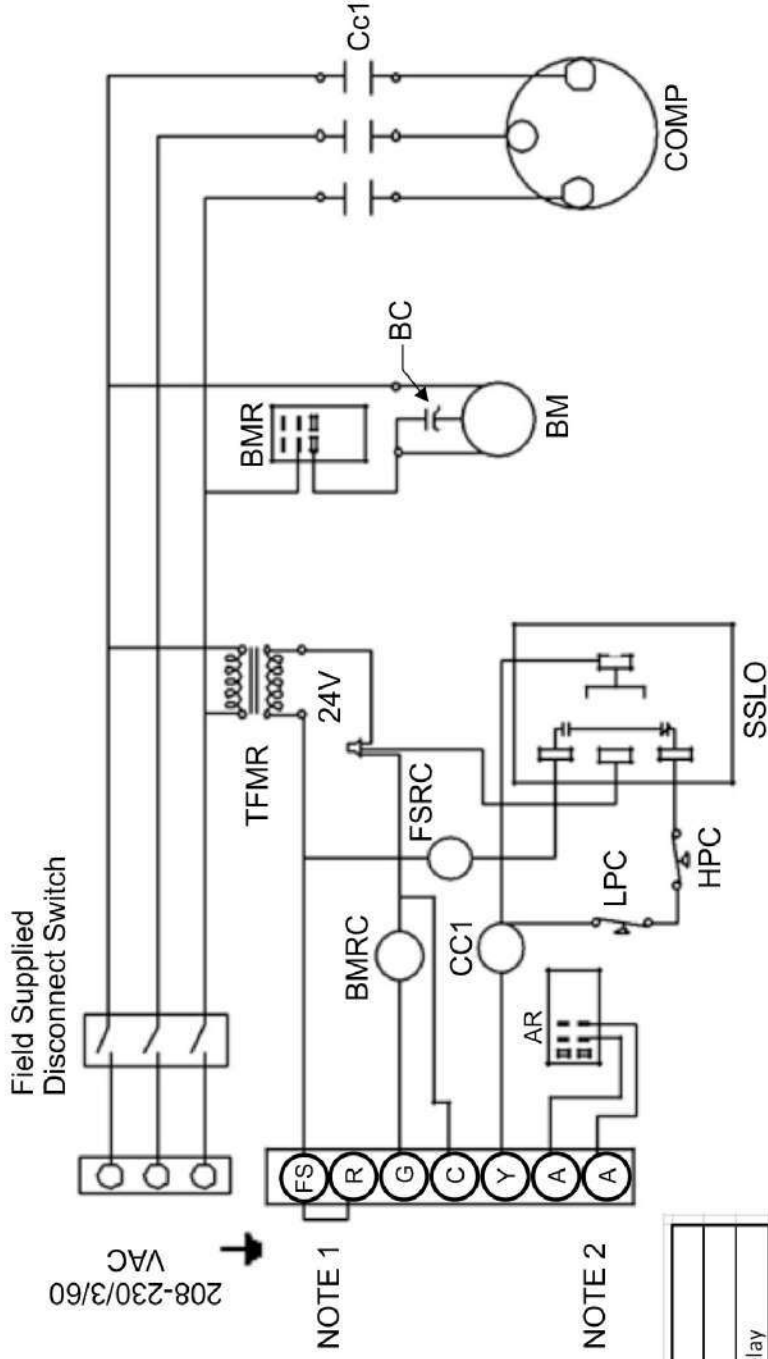

NOTE 1

NOTE 2

LEGEND	
BM	Blower Motor
BMR	Blower Motor Relay
BMRC	Blower Motor Relay Control
C1	Contact 1
CC1	Contact Coil 1
COMP	Compressor
DS	Disconnect Switch
FSR	Fire Stat Relay
FSRC	Fire Stat Relay Coil
HPC	High Pressure Control
SSLO	Solid State Lock-Out
TFMR	Transformer
C	Capacitor
A	Alarm Contact
AR	Alarm Relay
LPS	Low Pressure Switch (Option)

**Notes:**

- 1 Remove jumper and install wires from fire alarm system. Contacts should be normally closed.
- 2 Alarm contacts are rated for 208/230 1 amp. Contact is normally open and closes on lock out from SSLO module.

**diamondAIR**

208-230/3/60  
460/3/60  
575/3/60

FIELD SUPPLIED  
DISCONNECT

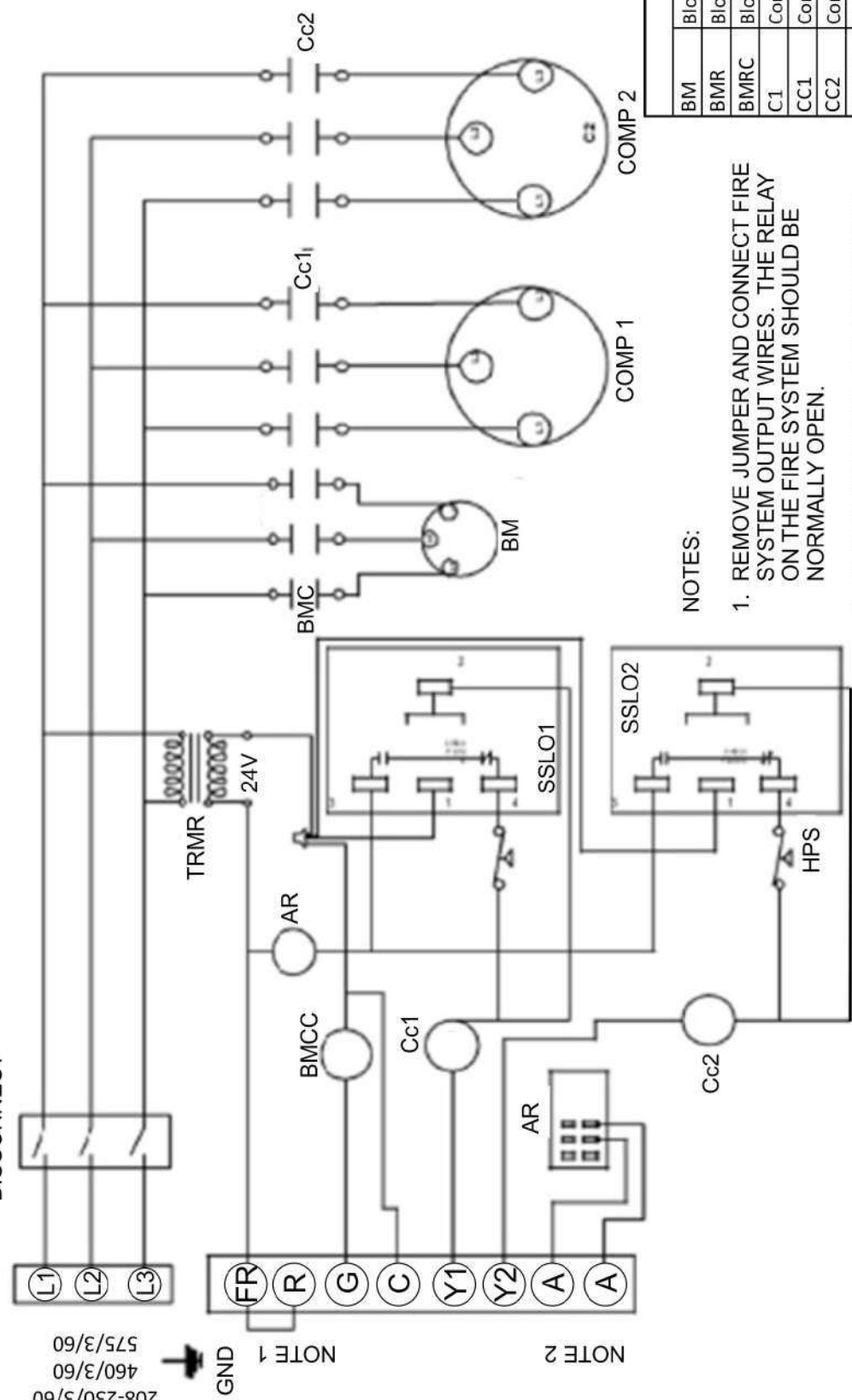

NOTE 1  
GND

NOTE 2

LEGEND	
BM	Blower Motor
BMR	Blower Motor Relay
BMRC	Blower Motor Relay Control
C1	Contactor 1
CC1	Compressor Contactor 2
CC2	Compressor Contactor 2
COMP	Compressor
DS	Disconnect Switch
FSR	Fire Stat Relay
FSRC	Fire Stat Relay Coil
HPC	High Pressure Control
SSLO1	Solid State Lock-Out 1
SSLO2	Solid State Lock-Out 1
TFMR	Transformer
C	Capacitor
A	Alarm Contact
AR	Alarm Relay
LPS	Low Pressure Switch (Option)

NOTES:

1. REMOVE JUMPER AND CONNECT FIRE SYSTEM OUTPUT WIRES. THE RELAY ON THE FIRE SYSTEM SHOULD BE NORMALLY OPEN.
2. ALARM CONTACTS ARE NORMALLY OPEN AND CLOSE ON LOCKOUT FROM SOLID STATE LOCKOUT MODULES.

**diamondAIR**  
LVA-LHA Schematic  
208-230/3/60 460/3/60 575/3/60

**MIT S AIRCONDITIONING INC.**  
**LIMITED WARRANTY**  
**diamondAIR HVAC EQUIPMENT**

1. MIT S AIRCONDITIONING INC. (“MIT S”) warrants to the original end user of this diamondAIR HVAC equipment (the “Equipment”) for the periods described below that the Equipment will be free of manufacturing defects. If the Equipment fails to operate under normal use due to a manufacturing defect within a period of one (1) year after the date of original installation of the Equipment, or in the case of a manufacturing defect in the compressor, within a period of five (5) years after such date, MIT S will at its option replace the defective part or compressor or part thereof without charge for the replacement or refurbished component. This warranty does not cover any labour, nor shipping or handling costs incurred. Any replacement or refurbished Equipment, compressor or part will be warranted against manufacturing defects for the remainder of the original warranty period. Parts used in connection with normal maintenance and parts subject to normal wear and tear, such as filters and belts, are not covered by this warranty.

2. To obtain warranty service, you must notify your dealer or contractor of any manufacturing defect in the Equipment within the applicable warranty period. This warranty does not cover any labour, nor shipping or handling costs incurred. You may be responsible for shipping or handling costs incurred in delivering defective Equipment or components or parts thereof for service or replacement unless your dealer or contractor has agreed to bear such costs.

3. MIT S sells this Equipment only to distributors who resell the Equipment to dealers or contractors. The dealers and contractors have sole and exclusive responsibility for the selection, application, suitability and installation of the Equipment with respect to all end users and their particular requirements. Dealers and contractors may also sell or furnish other products and equipment not supplied by or on behalf of MIT S for use in conjunction with the Equipment. Accordingly, MIT S makes no warranty or condition whatsoever and assumes no liability or obligation whatsoever with respect to: (a) any representation, warranty, promise or statement made by any dealer or contractor with respect to any Equipment *or* part thereof or the use or application thereof; (b) any acts or omissions of any dealer or contractor in selecting, recommending, installing, servicing, repairing, dismantling, moving or removing any Equipment or part thereof; or (c) any products, equipment, components, accessories or materials furnished or sold to you by a dealer or contractor other than the Equipment. Your dealer or contractor may provide a separate warranty for the products and services it supplies to you in addition to the Equipment and you are advised to confirm the terms and conditions of such warranty with your dealer or installer.

4. Any replaced Equipment, compressor or part will become the property of MIT S when exchanged for its replacement. MIT S reserves the right of inspection or refurbishing of its equipment at its discretion.

5. Proof of the original date of installation of the Equipment must be presented in order to establish the effective date of this warranty. Otherwise, the effective date will be deemed to be the date which is 30 days after the date of manufacture of the Equipment. The return of the Owner Registration Card is not a condition of the warranty. However, please complete, detach and return the Card so that we can contact you should any question arise which may affect your Equipment.

6. This warranty applies only: (a) while the Equipment remains at the site of original installation (except for Equipment designed for portable use); (b) to Equipment installed in Canada; and (c) if the Equipment is installed, maintained and operated in accordance with the manufacturer’s written instructions accompanying the Equipment and in compliance with all applicable laws, regulations, codes and bylaws. This warranty does not cover damage caused by: (a) accident, abuse, negligence or misuse; (b) operation of the Equipment in a corrosive atmosphere containing chlorine, fluorine or *any* other damaging chemicals; (c) improper matching or combination of other products, equipment, parts accessories or components with the Equipment; (d) modification or alteration of the Equipment; (e) repair or service by unqualified or unauthorized persons; (f) failure to install or operate the Equipment or to provide proper maintenance or service according to the manufacturer’s instructions; or (g) improper application or use of the Equipment; lightning, fluctuations in electrical power ;or (f) Acts of God, acts of war both declared and undeclared, acts of terrorism or use of the equipment in any unlawful application.

7. **THE FOREGOING CONSTITUTES YOUR SOLE AND EXCLUSIVE REMEDY AND THE SOLE AND EXCLUSIVE LIABILITY AND OBLIGATION OF MIT S IN CONNECTION WITH THE EQUIPMENT. THIS WARRANTY IS IN SUBSTITUTION FOR AND EXCLUDES ALL OTHER WARRANTIES AND CONDITIONS, EXPRESS OR IMPLIED, INCLUDING THE WARRANTIES AND CONDITIONS OF MERCHANTABILITY AND FITNESS FOR ANY INTENDED OR PARTICULAR PURPOSE. UNDER NO CIRCUMSTANCES WILL MIT S BE LIABLE TO THE PURCHASER OF THE EQUIPMENT OR ANY OTHER PERSON FOR ANY INCIDENTAL, SPECIAL OR CONSEQUENTIAL DAMAGE OR LOSS, WHETHER ARISING OUT OF BREACH OF CONTRACT, BREACH OF WARRANTY OR TORT, AND WHETHER OR NOT MIT S KNEW OR OUGHT TO HAVE KNOWN OF THE POSSIBILITY OF SUCH DAMAGE OR LOSS.**

8. This warranty gives you specific legal rights, and you may have other rights which may vary from Province to Province. In the event that portions of this warranty may be struck down in your jurisdiction, this does not render the remaining portions of this warranty to be void.

9. This warranty applies only to Equipment sold in Canada by MIT S and installed and used in Canada. This warranty is not transferable.

**MIT S AIRCONDITIONING INC.**  
1608 Bonhill Road  
Mississauga, Ontario, L5T 1C7