



MITS AIR™ Inverter Compressor
Side Discharge Condensing Unit
Installation / Service Manual

Cooling Only Models with Interface (MA24VA2/C)

MOBA30-11CFN1-MQ0W | 1 Ton

MOBA30-17CFN1-MR0W | 1.5 Ton

MOCA30-22CFN1-MR0W | 2.0 Ton



Table of Contents

Important	2
Warning	2
Important Installation Considerations	3-4
Refrigerant Gases	4
Electrical Work Warnings	5
Outdoor Unit Installation	6
Extreme Weather Conditions	7
Anchoring	7
Bracketing	8
Unit Dimensions & Clearances	8-9
Wiring	10
Refrigerant Tubing Connection	11
Connection Instructions	11-13
Instructions for Connecting Flares	13
Pressure Testing & Evacuation	14-15
Connecting Piping	16
Evacuation and Opening the System	17-18
Installing the Interface	18
Test Run	19
Start-up Report Form	20
Wiring Diagrams	21-24
Additional Refrigerant Charge Chart	25
Unit Data	26
Limited Warranty	27

Important: Legislation for Compliance within Canada

This manual is intended for use by personnel qualified by Federal, Provincial, and Municipal licensing in Canada and skill recognitions as required in the jurisdiction in which the equipment is being installed. Appropriate permits must be taken out as required in that jurisdiction in which the equipment is being installed and reporting of installation as required by law are the responsibility of the installer or contractor as obligated by law.

The installation must conform and comply with all applicable Federal, Provincial, and Municipal statutes, regulations, codes, ordinances, and bylaws in Canada. These take precedence over this manual.

Leak testing must be done in compliance with all applicable Federal, Provincial, and Municipal statutes, regulations, codes, ordinances, and bylaws in Canada. If you are unsure of your requirements, consult your local authority having jurisdiction.

All installation and service work must be completed by qualified and appropriately licensed individual in accordance with all Federal, Provincial, and Municipal statutes, regulations, codes, ordinances, and bylaws in Canada.

WARNING

Read safety precautions and review instructions before starting installation!

Incorrect installation due to ignoring instructions can cause serious damage or injury. The seriousness of potential damage or injuries is classified as either a WARNING or CAUTION.

WARNING

- Do not use an extension cord to power the unit.
- Do not share the electrical circuit with any other appliance. Improper or insufficient power supply can cause fire, electrical shock, or failure.
- When connecting refrigerant piping, do not allow contamination of the line set. The presence of other gases or substances will lower the unit capacity, and can cause abnormally high pressure in the refrigeration cycle. This can cause explosion and injury.
- Do not allow children to play with the air conditioner. Children must be supervised around the unit at all times.

Important Installation Considerations

1. **The metering device must be removed from the indoor coil.**
2. The liquid line and the gas line from the outdoor unit to the indoor coil must be insulated.
3. The thermostat must be used or configured as a single stage or 2 stage thermostat. See pages 21-22.
4. The interface box power wiring must be wired with approved cabling complying with the Canadian Electrical Code and the Provincial Electrical code in which the equipment is being installed. The power wiring must comply with the wiring type and applicable conduits as required by these codes.
5. All wiring and installation work must be properly arranged to ensure that the control board cover can close properly. If the control board cover is not closed properly, it can lead to corrosion and cause the connection to fail.
6. For all electrical work, follow all local and national wiring standards, regulations, and the Installation Manual. An independent circuit to supply power must be used. Do not connect other appliances to the same circuit. Insufficient electrical capacity or defects in electrical work can cause electrical shock or fire or cause the appliance to fail.
7. For all electrical work, use the specified cables and conform to all applicable codes and ordinances. Improper electrical connections can overheat and cause fire, and may also cause shock.
8. Installation must be performed by an authorized dealer or specialist that is licensed under all applicable statutes, regulations, codes, ordinances, and bylaws.
9. Installation must be performed according to the installation instructions. Improper installation can cause water leakage, electrical shock, or fire. Equipment must be installed in accordance with applicable building codes, ordinances, B51, B52, the Canadian Electrical Code, and the Electrical Code of the Province in which the system is installed.
10. An authorized and appropriately licensed service technician must be contacted for repair or maintenance of this unit.
11. Only use the included accessories, parts, and specified parts for installation. Using non-standard parts can cause water leakage, electrical shock, fire, and can cause the unit to fail.
12. Install the unit in a firm location that can support the unit's weight. If the chosen location cannot support the unit's weight, or the installation is not done properly, the unit may drop and cause serious injury and damage.



CAUTION

Do not install the unit close to an electrical or gas meter as regulated in the jurisdiction where the equipment is being installed.

Do not install the unit in a location that may be exposed to combustible gas leaks. If combustible gas accumulates around the unit, it may cause fire.

The product must be properly grounded at the time of installation, or electrical shock may occur.

Note About Fluorinated Refrigerant Gases

1. This air conditioning unit contains fluorinated gases. For specific information on the type of gas and the amount, please refer to the label on the unit itself.
2. Installation, service, maintenance, and repair of this unit must be performed by a certified technician licensed to do so under all applicable Federal, Provincial, and Municipal laws within Canada.
3. Product uninstallation and recycling must be performed by a certified technician in accordance with applicable Federal, Provincial, and Municipal requirements within Canada.
4. When the unit is checked for leaks, proper record-keeping of all checks is strongly recommended.
5. Leak testing and leak testing certificates that are required in the jurisdiction where the equipment is installed is the responsibility of the installer or the contractor as required by law.



**BEFORE PERFORMING ANY ELECTRICAL OR WIRING WORK,
TURN OFF THE POWER TO THE SYSTEM!**



BEFORE PERFORMING ELECTRICAL WORK, READ BELOW:

1. All wiring must comply with local and national electrical codes, and must be installed by a licensed electrician.
2. All electrical connections must be made according to the Electrical Connection Diagram located on the panels of the interface and outdoor units.
3. If there is a serious safety issue with the power supply, stop work immediately. Explain your reasoning to the client and refuse to install the unit until the safety issue is properly resolved.
4. Power voltage should be within 90-110% of rated voltage. Insufficient power supply can cause malfunction, electrical shock, or fire.
5. Install a CSA certified surge protector where there is a possibility of power surges or lightening strikes.
6. If connecting power to fixed wiring, install a surge protector and line of sight disconnect switch with a horsepower capacity exceeding the range of the unit.
7. Only connect the unit to a dedicated branch circuit. Do not connect another appliance to that outlet.
8. All wiring must be installed in accordance with the Canadian Electrical Code or the Provincial Electrical Code applicable to the jurisdiction that the equipment is being installed. The contractor is responsible for any required permits.
9. Make sure to properly ground the air conditioner.
10. Every wire must be firmly connected. Loose wiring can cause the terminal to overheat, resulting in product malfunction and possible fire.
11. Do not let wires touch or rest against refrigerant tubing, the compressor, or any moving or vibrating parts within the unit.

Outdoor Unit Installation

Step 1: Select installation location before installing the outdoor unit. The following are standards that will assist with choosing an appropriate location for the unit. Proper installation locations must meet the following standards:

- ✓ Meets all spatial requirements shown in Installation Space Requirements (refer to Fig. 4.1).
- ✓ Good air circulation and ventilation
- ✓ Firm and solid – the location can support the unit and will not vibrate.
- ✓ Noise from the unit will not disturb others.
- ✓ Protected from prolonged periods of direct sunlight, rain, or snow.

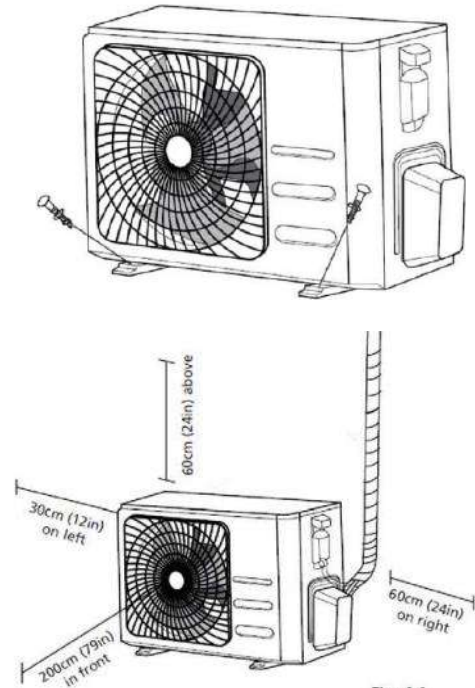

Fig. 4.1

DO NOT install the unit in the following locations:

- ✗ Near an obstacle that will block air inlets and outlets.
- ✗ Near a public street, crowded areas, or where noise from the unit will disturb others.
- ✗ Near animals or plants that will be harmed by hot air discharge.
- ✗ Near any source of combustible gas or in a location that is exposed to large amounts of dust.
- ✗ In a location exposed to excessive amounts of salty air.

Special Considerations for Extreme Weather Conditions

If the unit is exposed to prevailing winds:

Install the unit so that air outlet is at a 90° angle to the direction of the wind. If needed, obtain wind baffles from your distributor to protect the unit from extremely heavy winds. See 4.2 and Fig. 4.3.

Caution: Heat pumps must be installed on a properly designed stand and have minimum 18" clearance from normal snow levels in the area.

Systems being installed in close proximity to salt water or other corrosive substances must be specially coated to prevent corrosion. Contact your distributor for guidance.

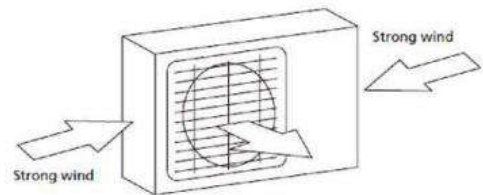

Fig. 4.2

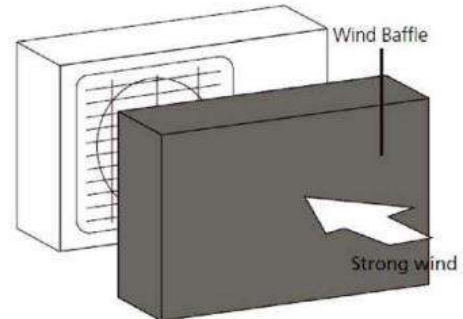

Fig. 4.3

Anchor Outdoor Unit

The outdoor unit can be anchored to the ground or to a wall-mounted bracket.

For cooling only units, if the unit is installed on the ground or on a concrete mounting platform, do the following:

1. Mark the positions for 4 expansion bolts required.
2. Pre-drill holes for expansion bolts.
3. Clean concrete dust away from holes.
4. Place a nut on the end of each expansion bolt.
5. Hammer expansion bolts into the pre-drilled holes.
6. Remove the nuts from the expansion bolts, and place outdoor unit on bolts.
7. Put washer on each expansion bolt, then replace the nuts.
8. Using a wrench, tighten each unit until snug.
9. Heat pumps must be elevated off grade / roof minimum 18" to ensure proper winter operation during defrost cycle.

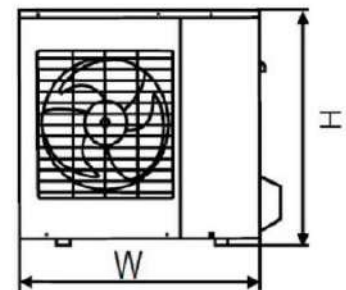
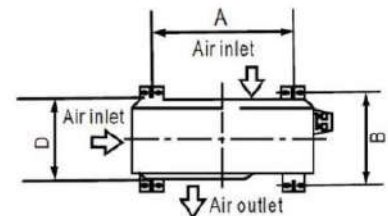

Figure 4.5





CAUTION

Before installing a wall-mounted unit, make sure that the wall is made of solid brick, concrete, or of similarly strong material (load bearing wall).

The wall must be able to support at least 4 times the weight of the unit.

Installing the unit on a wall-mounted bracket:

1. Mark the position of bracket holes based as needed.
2. Pre-drill the holes for the expansion bolts.
3. Clean dust and debris away from holes.
4. Place a washer and a nut on the end of each expansion bolt. Thread expansion bolts through holes in mounting brackets, put mounting brackets in position, and hammer expansion bolts into the wall.
5. Check that the mounting brackets are level.
6. Carefully lift unit and place its mounting feet on brackets.
7. Bolt the unit firmly to the brackets.

Unit Dimensions

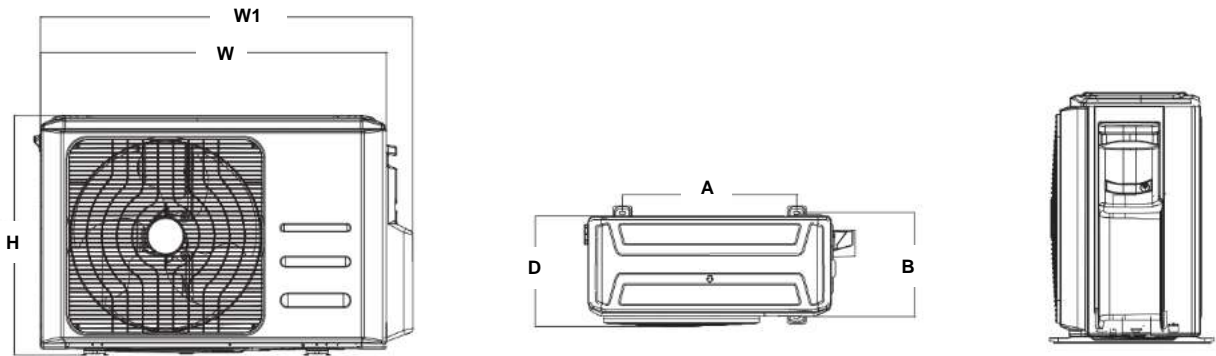

Model	Unit	Dimensions					
		W	D	H	W1	A	B
MOBA30-11CFN1-MQ0W	Inches	30.31	11.81	21.85	33.07	19.17	11.73
MOBA30-17CFN1-MR0W	Inches	30.31	11.81	21.85	33.07	19.17	11.73
MOCA30-22CFN1-MR0W	Inches	33.27	14.29	27.64	35.98	21.26	13.78

Minimum Clearance for Outdoor Unit

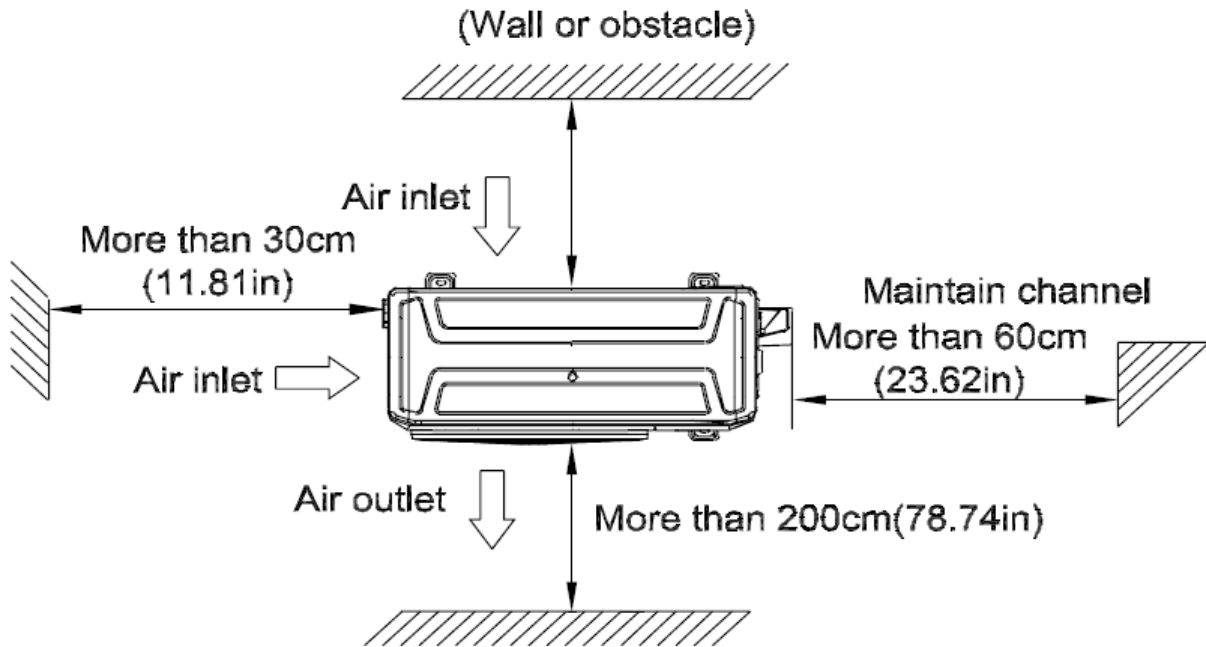

Multiple Unit Clearances for Outdoor Units

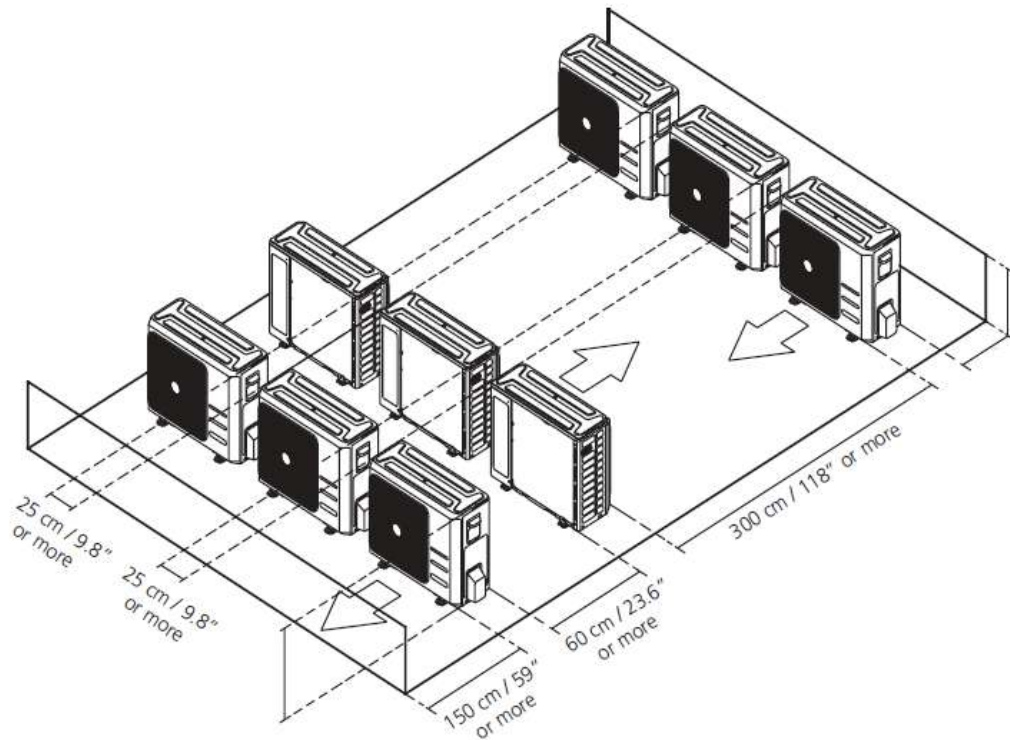



WARNING

BEFORE PERFORMING ANY ELECTRICAL OR WIRING WORK, TURN OFF THE MAIN POWER TO THE SYSTEM.

ALL WIRING MUST BE PERFORMED STRICTLY IN ACCORDANCE WITH THE LOCAL CODE WITHIN CANADA.

1. Prepare the cable for connection:
 - a. Using wire strippers, strip the rubber jacket from both ends of cable to reveal about 40mm (1.57 in) of the wires inside.
 - b. Strip the insulation from the ends of the wires.
 - c. Using a wire crimper, crimp a CSA certified fork terminal on the ends of the wires.
2. Unscrew the electrical wiring cover and remove it. Unscrew the cable clamp below the terminal block and place it to the side.
3. Match the wire colours/labels with the labels on the terminal block, and firmly screw the lug screw to the wire and its corresponding terminal.
4. After checking to make sure every connection is secure, make a drop loop with the wires to prevent rainwater from flowing into the terminal.
5. Using the cable clamp, fasten the cable to the unit. Screw the cable clamp down tightly.
6. Insulate unused wires with a wire nut and PVC electrical tape. Arrange them so that they do not touch any electrical or metal parts.
7. Replace the wire cover on the side of the unit, and screw it in place.
8. Refer to pages 23 and 24.



CAUTION

ALL PORTIONS OF THE CANADIAN ELECTRICAL CODE OR THE PROVINCIAL ELECTRICAL CODE IN WHICH THE EQUIPMENT IS INSTALLED IN, MUST BE FOLLOWED. WIRE SIZING AND TYPE, MECHANICAL PROTECTION AND WEATHER PROOFING TAKES PRECEDENCE OVER THIS MANUAL.

A LINE OF SIGHT DISCONNECT AT THE OUTDOOR UNIT MUST BE USED FOR THE POWER COMING FROM THE DISTRIBUTION BOX, IT MUST HAVE A CERTIFIED HORSE POWER RATING EXCEEDING THE OUTDOOR UNIT RATING.

REQUIRED PERMITS ARE THE RESPONSIBILITY OF THE CONTRACTOR PERFORMING THE WORK.

Refrigerant Tubing Connection

Note on Pipe Length:

The length of refrigerant piping will affect the performance and energy efficiency of the unit. Nominal efficiency is tested on units with a pipe length in North America of 7.5 m (25').

A minimum pipe run of 3 meters (10 ft) is required to minimize vibration and excessive noise.

Refer to the table below for specifications on the max length and drop height of piping.

Maximum Length and Drop Height of Refrigerant Piping per Unit Model

Model	Capacity (Btu/hr)	Max Length		Max Height	
		ft	m	ft	m
R401A Inverter Split Air Conditioner	< 15,000	82	25	33	10
	> 15,000 and < 23,000	99	30	66	20

Connection Instructions – Refrigerant Tubing

Step 1: Cut Tubing

When preparing refrigerant pipes, take extra care to cut and flare them properly. This will ensure efficient operation and minimize the need for future maintenance.

1. Measure the distance between the indoor and outdoor units.
2. Using a tube cutter, cut the pipe a little longer than the measured distance.
3. Make sure that the tube is cut at a perfect 90° angle. Refer to Fig. 5.1 for bad cut examples.

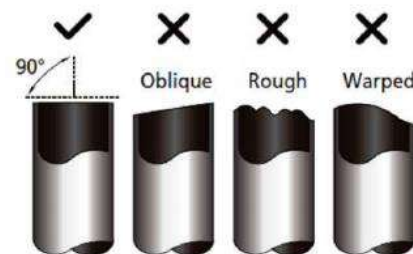

Fig. 5.1

Be extra careful not to damage, dent, or deform the tube while cutting. This will drastically reduce the efficiency of the unit.

DO NOT DEFORM TUBE WHILE CUTTING

Step 2: Remove Burrs

Burrs can affect the air-tight seal of refrigerant piping connection. They must be completely removed.

1. Hold the pipe at a downward angle to prevent burrs from falling into the tubing.
2. Using a reamer or deburring tool, remove all burrs from the cut section of the tubing.
3. Take care not to score the wall during deburring. This will cause a leak.

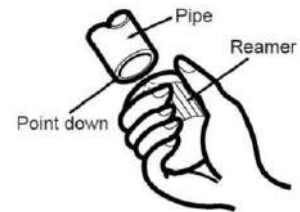

Fig. 5.2

Step 3: Flare Tubing Ends

Proper flaring is essential to achieve an airtight seal.

1. After removing burrs from cut tube, seal the ends with PVC tape to prevent foreign materials from entering the tube.
2. Sheath the tubing with insulating material.
3. Place flare nuts on both ends of tubing. Make sure they are facing in the right direction, because they cannot be put on or have their direction changed after flaring. See Fig. 5.3.
4. Remove PVC tape from ends of the tube when ready to perform flaring work.
5. Clamp flare form on the end of the tube. The end of the tube must extend beyond the edge of the flare form in accordance with the dimensions shown in the table below. See Fig. 5.4.

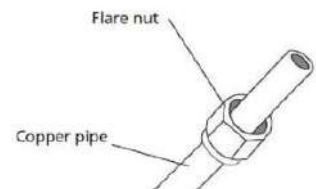

Fig. 5.3

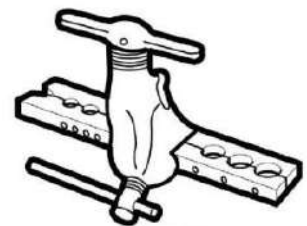

Fig. 5.4

PIPING EXTENSION BEYOND FLARE FORM

Outer Diameter of Pipe (mm)	A (mm)	
	Min.	Max.
Ø 6.35 (Ø 0.25")	0.7 (0.0275")	1.3 (0.05")
Ø 9.52 (Ø 0.375")	1.0 (0.04")	1.6 (0.063")
Ø 12.7 (Ø 0.5")	1.0 (0.04")	1.8 (0.07")
Ø 16 (Ø 0.63")	2.0 (0.078")	2.2 (0.086")
Ø 19 (Ø 0.75")	2.0 (0.078")	2.4 (0.094")

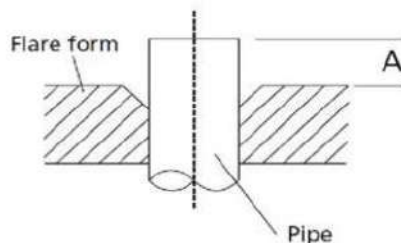

Fig. 5.5.



CAUTION – DO NOT USE EXCESSIVE TORQUE

Excessive force can break the nut or damage the refrigerant tubing. Torque requirements must not exceed values as shown in the table below.

Step 4: Connect Tubes

When connecting refrigerant tubing, be careful not to use excessive torque or to deform the tubing in any way. First connect the low-pressure pipe, then the high-pressure lines.

MINIMUM BEND RADIUS

When bending connective refrigerant tubing, the minimum bending radius is 10 cm. See Fig. 5.6.

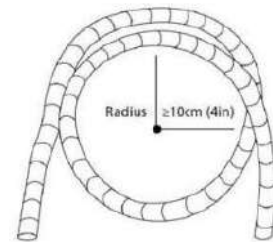

Fig. 5.6

Instructions for Connecting Flares

1. Align the center of the two tubes that will connect. See Fig. 5.7.
2. Tighten the flare nut as tightly as possible by hand.
3. Using a spanner, grip the nut on the unit tubing.
4. While firmly gripping the nut on the unit tubing, use a torque wrench to tighten the flare nut according to the torque values in the **Torque Requirements** table below. Loosen the flaring. See Fig 5.8.

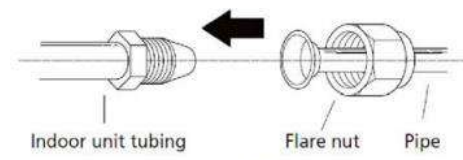

Fig. 5.7

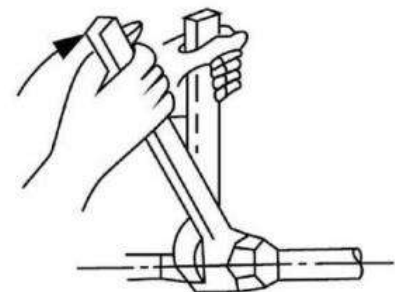
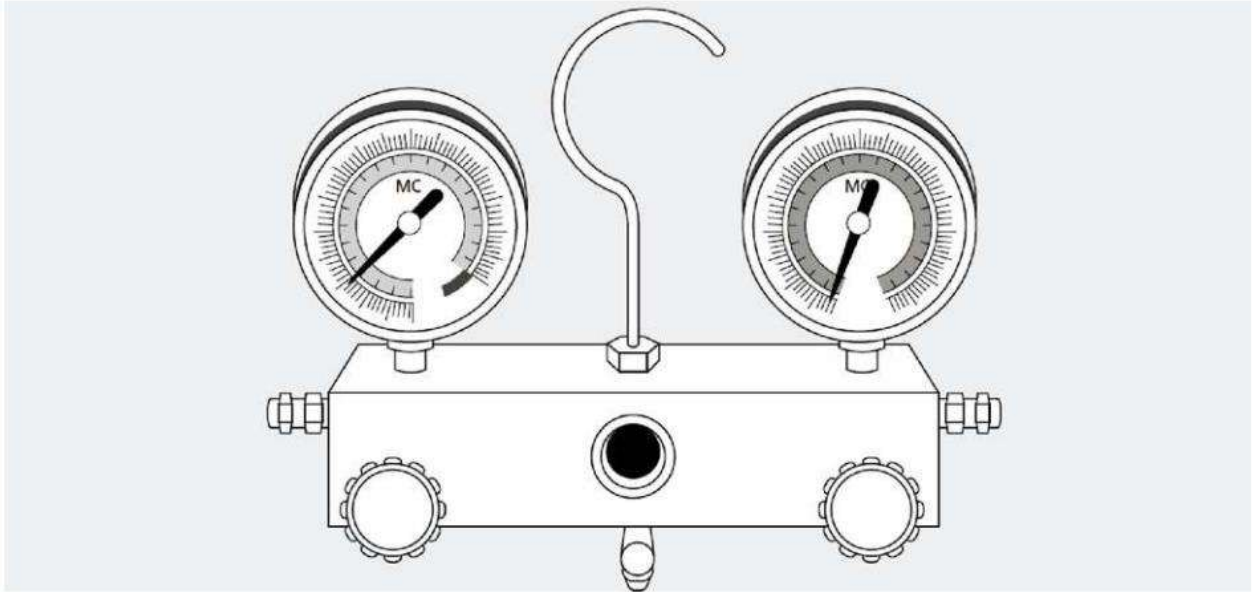

Fig. 5.8

Repeat Steps 3 to 6 for the remaining pipe. Torque Wrench Specification				
Tubing Size		Wrench Size (mm)	Torque	
IN	mm		N-M	ft-lb
1/4	6.35	17	14-18	10-13
1/2	12.70	24	49-61	35-44
3/8	9.52	22	34-42	25-30
5/8	15.88	26	68-82	49-59

Pressure Testing and Evacuation



WARNING

This procedure is intended for professionals with appropriate certification and licensing in the jurisdiction that the equipment is installed in. This procedure requires the use of high-pressure gasses that if incorrectly used can cause injury and death.

Ensure the maximum test pressure of your indoor coil. **Under no circumstances should the testing exceed 450 psig!**

The appropriate personal safety protection equipment including gloves and safety glasses must be worn at all times.

Pressure test the system using dry nitrogen:

1. Secure the pressure gas tank securely to ensure it does not fall over and damage the regulator or hoses.
2. Install a nitrogen regulator certified for pressures exceeding the test and ensure the connection nut is adequately torqued.
3. Open the regulator output pressure knob so that it is loose.

4. Connect your manifold center hose to the regulator and your high-pressure hose to the machine. You will require a 1/4" to 5/16" hose adaptor to do this.
5. Open the main high pressure valve of the tank and ensure that the regulator is not leaking. Begin closing the output pressure of the regulator to begin delivering nitrogen to the hoses, and stop at 75 psig.
6. Slowly open the high pressure of the manifold and slowly fill the lines to 75 psig. Mark your gauge cover with a pencil indicating the leading edge of the gauge needle, turn off the main valve of the tank and wait 10 minutes.
7. If the needle has not indicated a pressure drop, open your main valve and slowly open the high pressure to increase the pressure to 150 psig. Shut off the main valve and mark the needle position with your pencil and hold for 10 minutes.
8. If there is no pressure drop, open the main valve and increase to 400 psig. Close the main valve and mark the manifold pressure gauge with a pencil.
9. If the pressure has not dropped after 35 minutes, slowly release the nitrogen to atmosphere and go to the evacuation procedure.
10. If there has been a pressure drop, use an approved leak detection sap solution to find the leak. Do not shake the solution before use! This will introduce bubbles to the solution and make leak detection impossible.
11. Repair the leak and repeat this procedure until leak(s) have been eliminated.

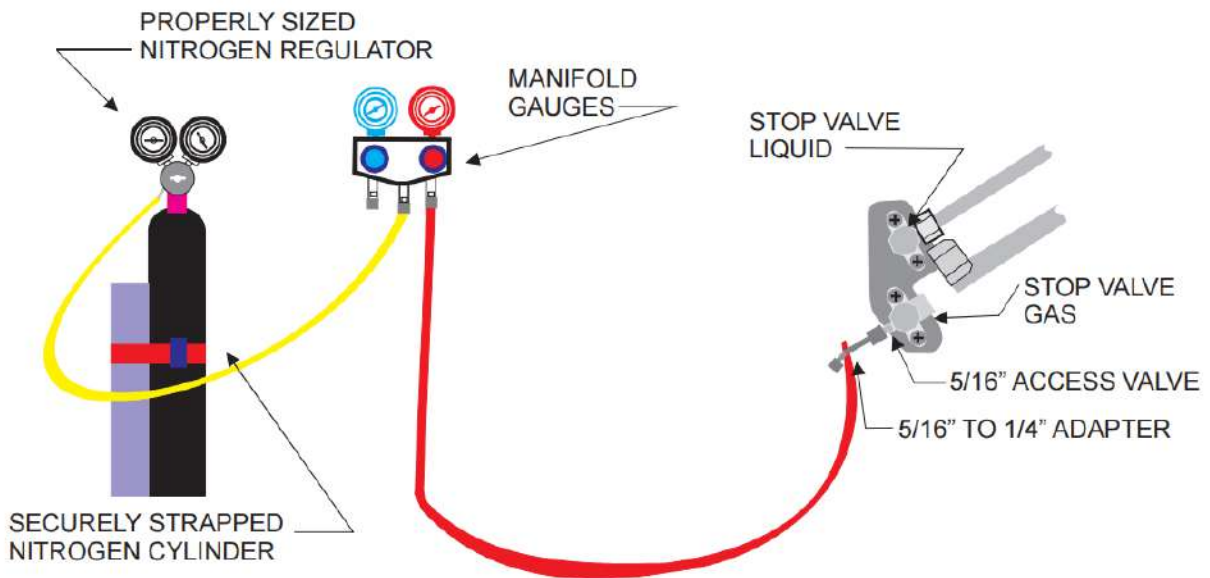

Instructions for Connecting Piping to Outdoor Unit



USE WRENCH TO GRIP MAIN BODY OF VALVE

Excessive torque can damage the valve, flare nuts, tubing, and snap off other parts of the valve.

1. Unscrew the cover from the packed valve on the side of the outdoor unit (see Fig. 5.9).
2. Remove protective caps from ends of valves.
3. Align flared tubing end with each valve, and tighten the flare nut as tightly as possible by hand.
4. Using a properly sized wrench, grip the body of the valve. Do not grip the nut that seals the service valve (see Fig. 5.10).
5. While firmly gripping the body of the valve, use a torque wrench to tighten the flare nut according to the correct torque values.
6. Loosen the flaring nut slightly, then tighten again.

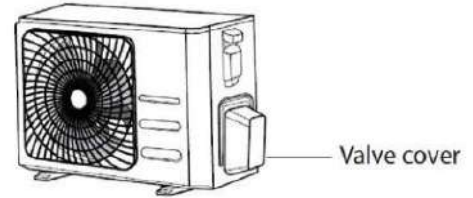

Fig. 5.9

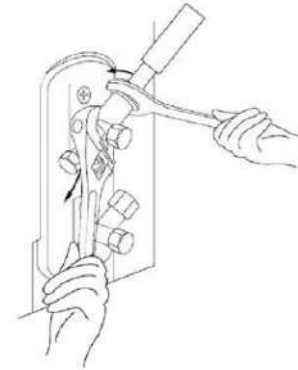

Fig. 5.10

Repeat Steps 3 to 6 for the remaining pipe.				
Torque Wrench Specification				
Tubing Size		Wrench Size	Torque	
IN	mm	mm	N-M	ft-lb
1/4	6.35	17	14-18	10-13
1/2	12.70	24	49-61	35-44
3/8	9.52	22	34-42	25-30
5/8	15.88	26	68-82	49-59

Evacuation and Opening the System

Preparations and Precautions

- Air and foreign matter in the refrigerant circuit can cause abnormal rise in pressure, which can damage the air conditioner, reduce its efficiency, and cause injury.
- Use a vacuum pump and manifold gauge to evacuate the refrigerant circuit, removing any condensable gas and moisture from the system.
- Evacuation should be performed upon initial installation and when unit is relocated.

Instructions

1. Connect the charge hose of the manifold gauge to service port on the outdoor units low pressure valve. Use the spare port to mount the micron gauge. Keep the micron gauge above the manifold to prevent oil from contaminating the sensor.
2. Connect charge hose from the manifold gauge central port to the vacuum pump.
3. Open both ports of the manifold gauge.
4. Turn on the vacuum pump to evacuate the system.
5. Run the vacuum for at least 15 minutes after the micron gauge reads 350 microns.
6. Close the isolation valve of the manifold, and turn off the vacuum pump and observe the micron gauge.
7. Wait for 10 minutes then check that there has been no change in system pressure.
8. If there is a change in system pressure, refer to Gas Leak Check section for information on how to check for leaks. If there is no change in system pressure, proceed to the next section.

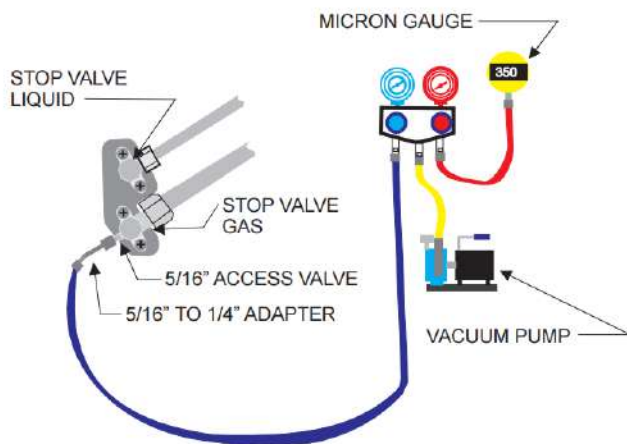

Opening the System

1. If the one-way length of refrigerant liquid line is greater than twenty-five feet (25'), consult the charge sheet in the rear of the manual and weigh in the charge adjustment. Refer to page 25.
2. Remove the cap of the gas line stop valve. **Use a metric Allen key** to open the valve and rotate the valve stem to its maximum opening. Finger tighten the cap back in place. Using a torque wrench, torque the cap to its specified setting.
3. Repeat the process for the liquid line stop valve.
4. Remove the charge hose from the service port and finger tighten the cap. Torque to the specified setting.

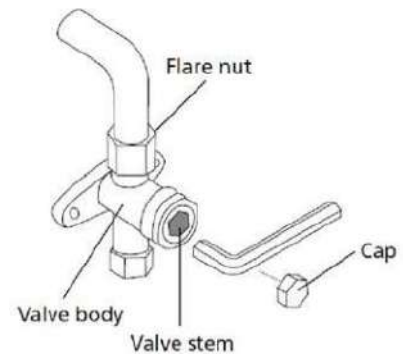

Stop Valve Torque Settings

Item	ft-lbs	Nm	kgf/cm
Line Port Cap	10-13	13.7 – 17.7	140 – 180
Stop Valve Cap	15-22	19.6 – 29.4	200 – 300

Installing the Interface

Installing the Interface

- The interface must be installed within 10' of the furnace return plenum.
- **Interface may not be installed outdoors.**
- The return air sensor must be installed in the return air plenum upstream from any device that may cause a temperature difference such as a humidifier.
- The return air sensor must be connected to the extension wire with the ferrite core (doughnut). Failure to do so may adversely affect the operation of the system.
- Ensure the dip switches are configured as shown on the appropriate wiring diagrams. If switches are changed, the power must be reset as the computer only reads switches on "POWER UP."
- When booted up, the display will only show "00." On cooling call, the display will go to "01." On completion of the call the display will go to either "00" or "03" (stand-by). Other numbers indicated either an incorrectly set dip switch or an error.
- Be sure to re-install the cover plate when finished.
- Refer to appropriate wiring diagrams on pages 21 and 22.

Test Run and Start-Up Report

Before Test Run

Only perform test run after the following steps have been completed:

- **Electrical Safety Checks** – Confirm that the unit's electrical system is safe and operating properly.
- **Gas Leak Checks** – Check all flare nut connections and confirm that the system is not leaking.
- **Valves** – Confirm gas and liquid (high and low pressure) valves are fully open.

Run the system for 30 minutes
and complete the start-up report.

Startup Form

	End User	Installer
Name		
Address 1		
Address 2		
City		
Province		
Postal Code		
Telephone Number		
Email		

	Outdoor Unit	Indoor Coil
Manufacturer	Mits Air™	
Model		
Serial No.		

Testing		Check List		
Ambient °F		Piston / TXV Removed	Y	N
Return Air °F		Liquid Line Insulated	Y	N
Supply Air °F		Gas Line Insulated	Y	N
Return Air Temp at RA Sensor °F		Dip Switch Positions Checked	Y	N
Fan Speed		Leak Test	Y	N
CFM Indoor				
Outdoor Unit Wire Size				
Interface Panel Wire Size				
Outdoor Volts				
Outdoor Amps				

Installer's Signature	Date of Start-up

Wiring Diagrams

MITS AIR COOLING ONLY PHYSICAL WIRING DIAGRAM FOR SINGLE-STAGE THERMOSTATS

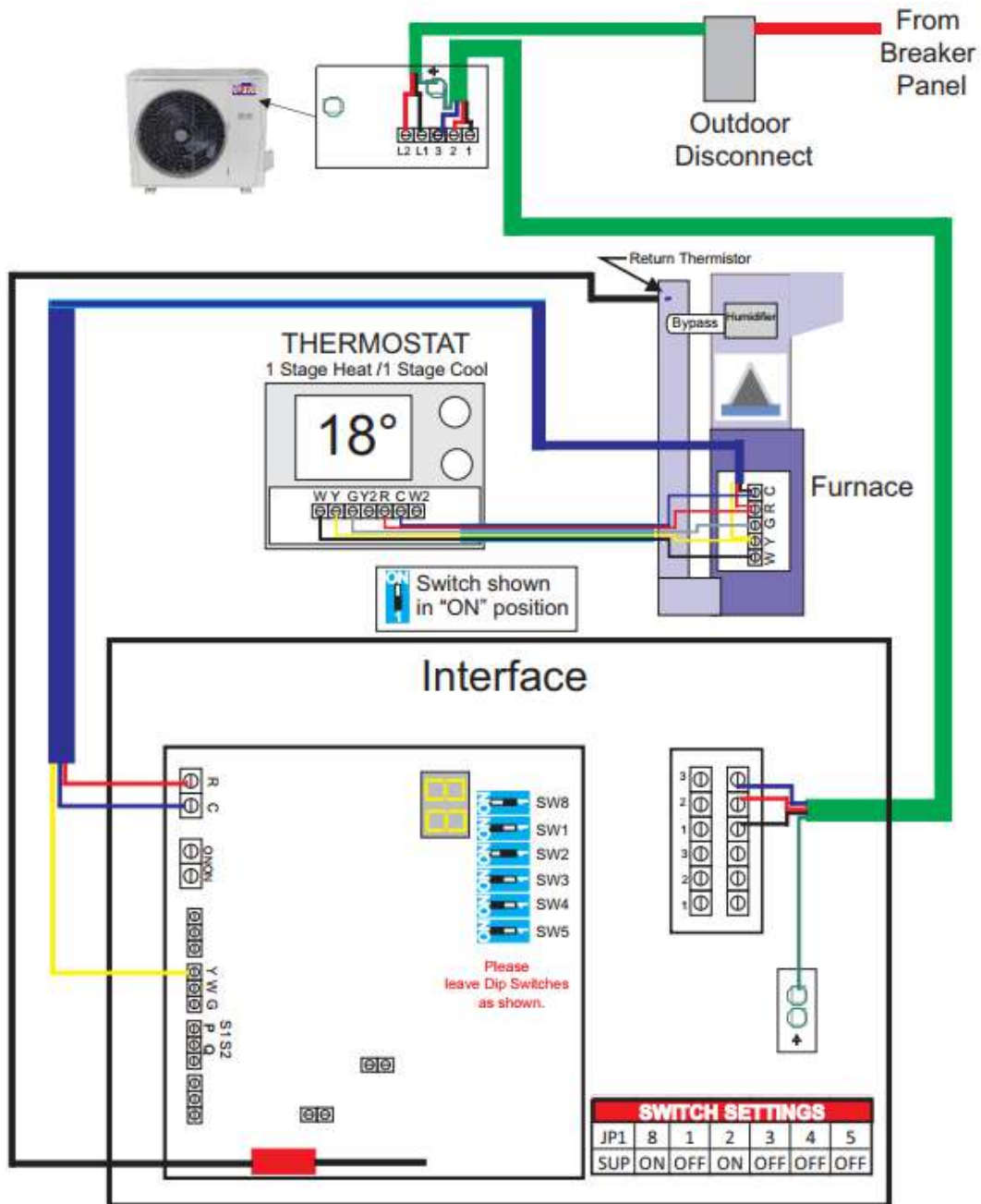

DIAGRAM SHOWS DEFAULT SETTINGS

MITS AIR COOLING ONLY PHYSICAL WIRING DIAGRAM FOR MULTI-STAGE THERMOSTATS

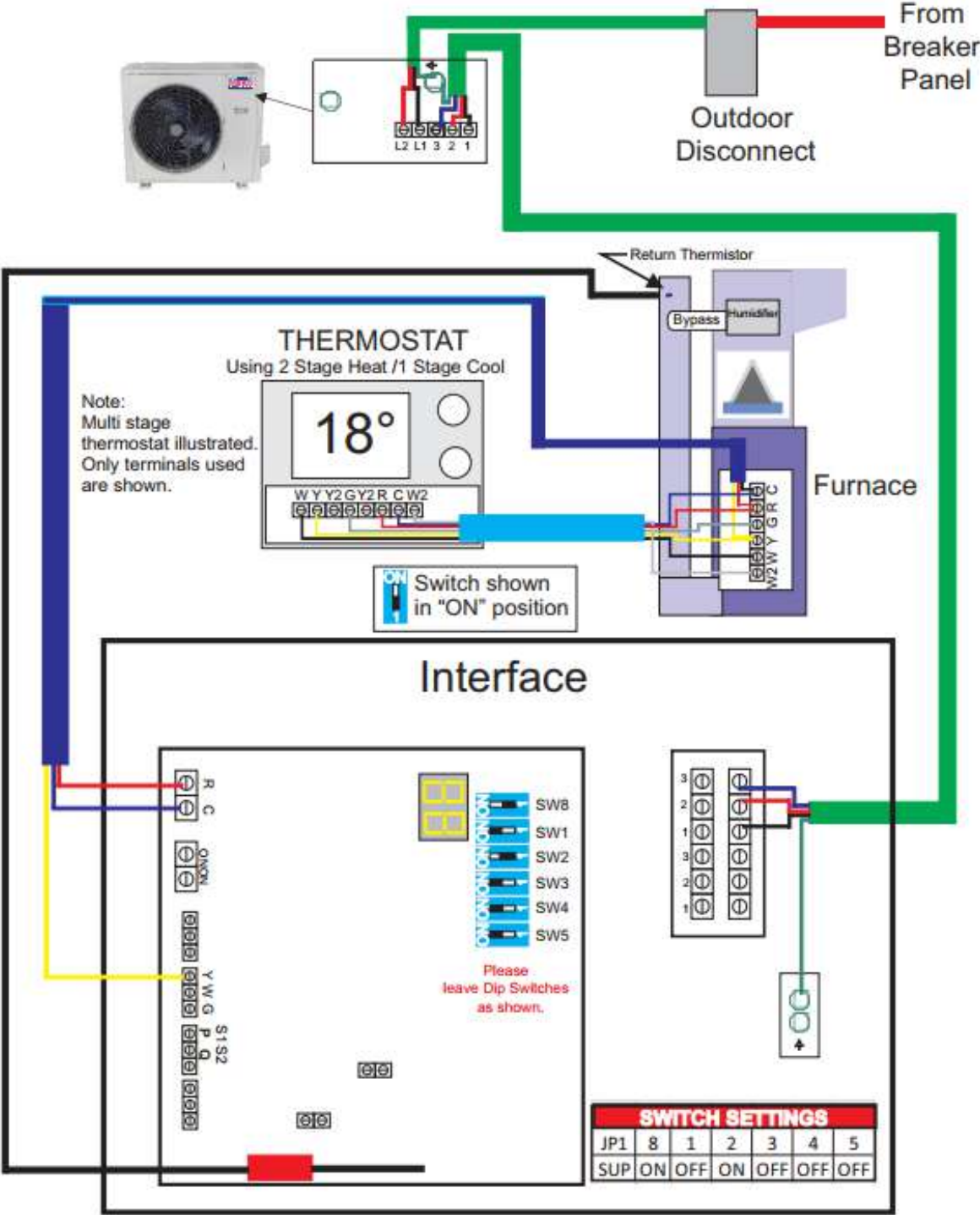
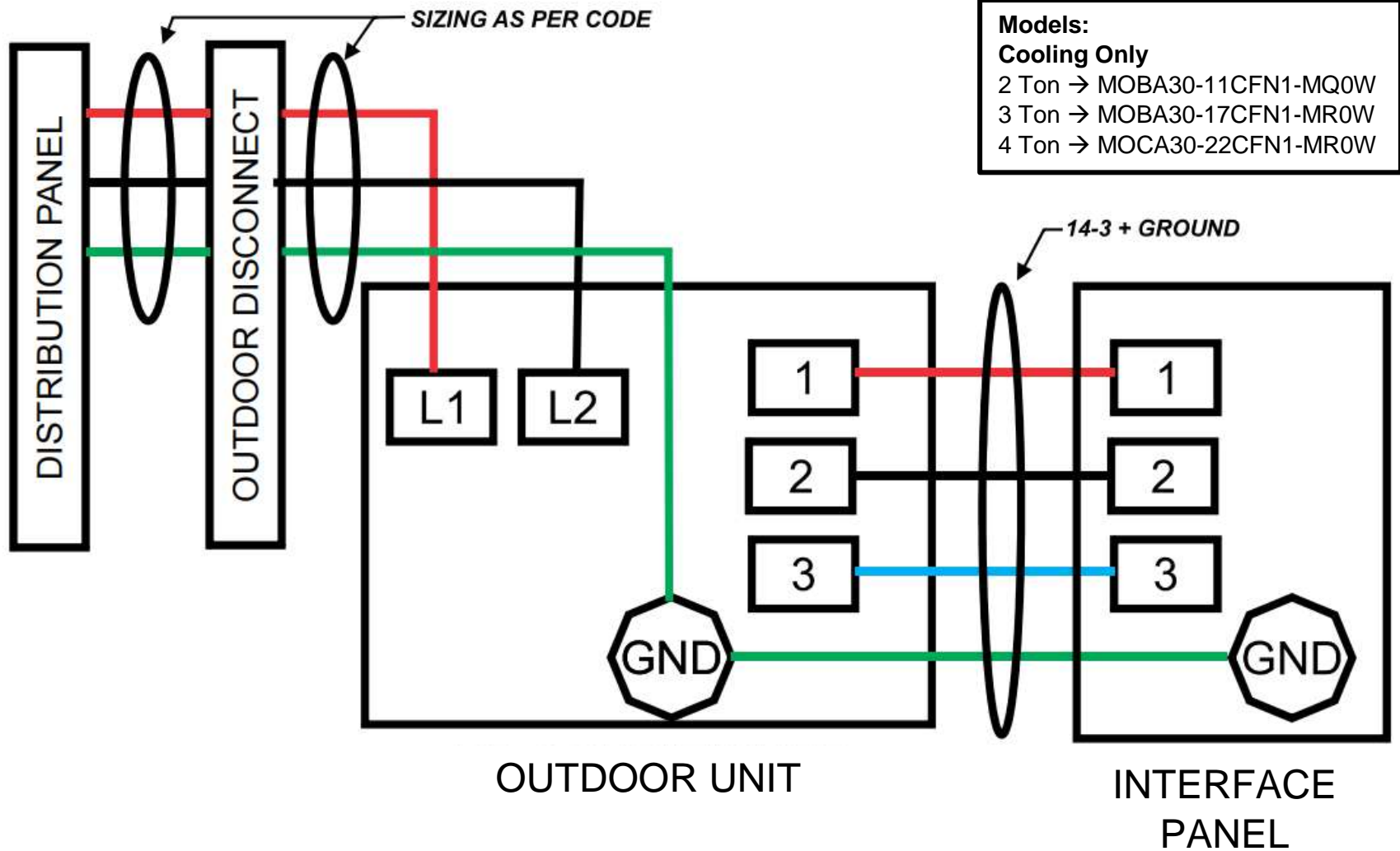

DIAGRAM SHOWS DEFAULT SETTINGS

SIMPLIFIED POWER WIRING FOR 1.0, 1.5, & 2.0 TON OUTDOOR UNITS



SIMPLIFIED LOW VOLTAGE WIRING FOR AIR CONDITIONER

Models:
Cooling Only
 1 Ton → MOBA30-11CFN1-MQ0W
 1.5 Ton → MOBA30-17CFN1-MR0W
 2 Ton → MOCA30-22CFN1-MR0W

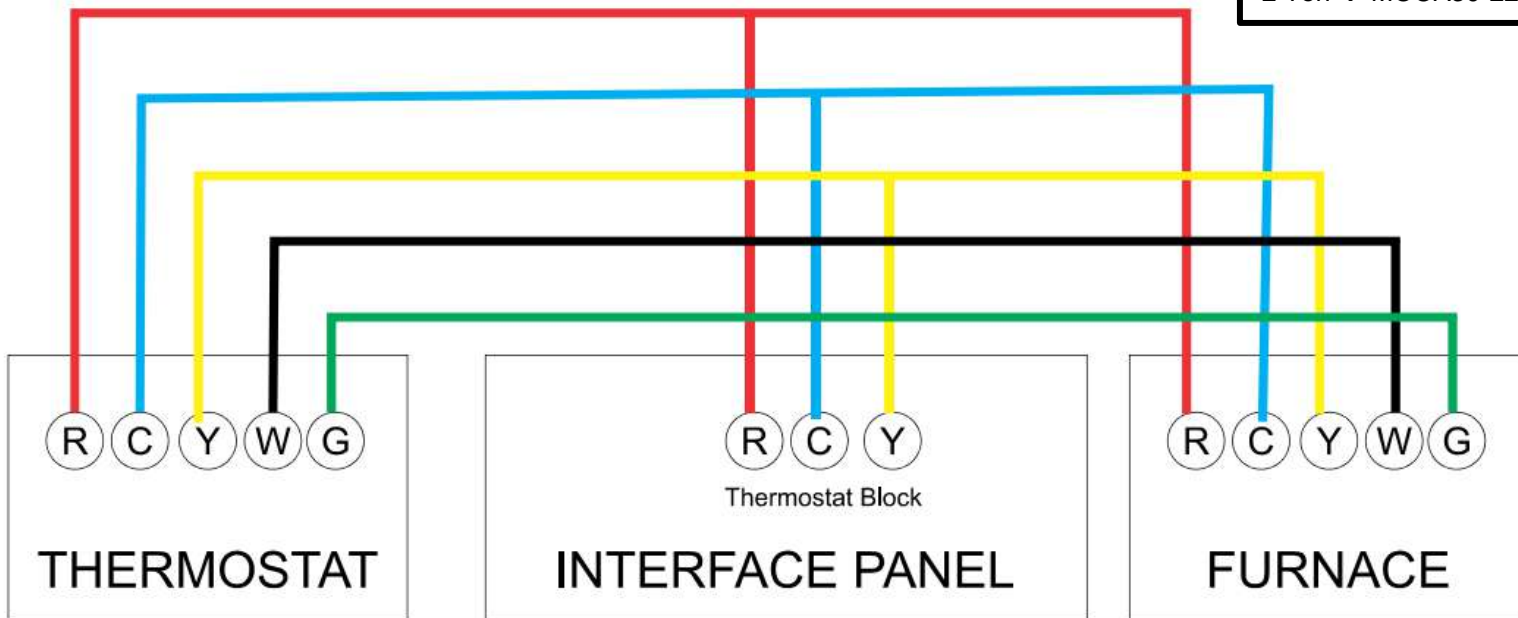

Page 24 of 27

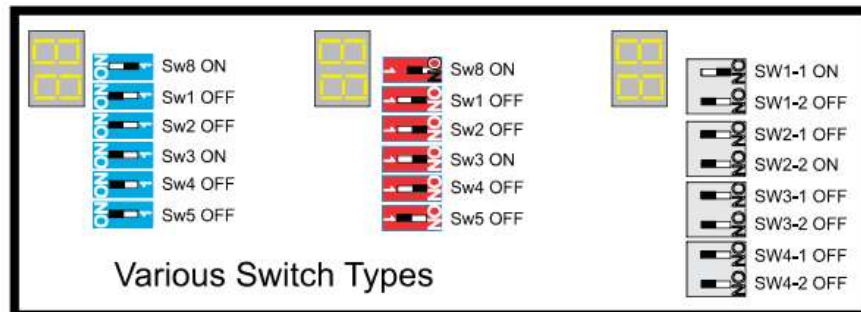

Additional Refrigerant Charge Chart

Cooling Only Models	Line Size		Maximum Line Lengths		Minimum Length	PRE CHARGE	Refrigerant Added to Liquid Line for Length (oz)														Each Additional 5'	
	Liquid Line	Suction Line	Total	Vertical			30'	35'	40'	45'	50'	55'	60'	65'	70'	75'	80'	85'	90'	95'		100'
MOBA30-11CFN1-MQ0W	1/4"	1/2"	82'	33'	15'	25'	0.8	1.6	2.4	3.2	4	4.8	5.6	6.4	7.2	8	8.8					0.8
MOBA30-17CFN1-MR0W	1/4"	1/2"	98'	66'	15'	25'	0.8	1.6	2.4	3.2	4	4.8	5.6	6.4	7.2	8	8.8	9.6	10	11		0.8
MOCA30-22CFN1-MR0W	3/8"	5/8"	98'	66'	15'	25'	0.8	1.6	2.4	3.2	4	4.8	5.6	6.4	7.2	8	8.8	9.6	10	11		0.8

Unit Data



Outdoor Model♦			MOBA30-11CFN1-MQ0W	MOBA30-17CFN1-MR0W	MOCA30-22CFN1-MR0W
Power supply		Ph-V-Hz	208-230V, 1Ph, 60Hz	208-230V, 1Ph, 60Hz	208-230V, 1Ph, 60Hz
Cooling	Capacity	Btu/h	11500	17000	22000
	Input	W	1037	1583	1960
	Rated current	A	4.5	6.7	9.0
	EER§	Btu/w	11.1	10.8	10.9
	SEER§	Btu/w	19	20	19
Minimum Circuit Ampacity		A	11	15	18
Max. Fuse		A	15	20	25
Compressor	Type		INVERTER	INVERTER	INVERTER
	Rated current (RLA)	A	6.8	9	12.0
Outdoor fan motor	RLA	A	0.39	0.39	0.6
Outdoor noise level		dB(A)	51.5	53.5	57
Outdoor unit	Dimension(W*D*H)	Inch	30.31 x 11.81 x 21.85	30.31 x 11.81 x 21.85	33.27 x 14.29 x 27.64
	Net/Gross weight	lbs.	54.67/59.52	65.92/72.31	88.62/95.90
Refrigerant type (Precharge)		oz	R410A (18.7)	R410A (31.7)	R410A (40.9)
Refrigerant precharge		ft	20	20	30
Additional charge for each ft		oz	0.21	0.21	0.32
Refrigerant piping	Liquid side/Gas side	Inch	1/4" / 1/2"	1/4" / 1/2"	3/8" / 5/8"
	Max. Refrigerant pipe length	ft	82	98	98
	Max. Difference in level	ft	33	66	66
Operation Temperature	Outdoor (cooling)	°C	-3 ~ 35	-3 ~ 35	-3 ~ 35
	Outdoor (cooling)	°F	25 ~ 95	25 ~ 95	25 ~ 95

§ All testing and values are per Manufacturer's testing and use of Manufacturer's coils.

♦ Outdoor unit includes Interface module MA24VA2/C

Limited Warranty: Mits Airconditioning Inc. MITS AIR™ Inverter Compressor Side Discharge Condensing Unit

1. MITS AIRCONDITIONING INC. ("MITS") warrants to the original end user of this MITS AIR™ Inverter Compressor Side Discharge Cooling Only Condensing Unit (the "Equipment") for the periods described below that the Equipment will be free of manufacturing defects. If the Equipment fails to operate under normal use due to a manufacturing defect, the Equipment has 5 year parts and 5 year compressor warranty effective from the date of installation. MITS will replace the defective part or compressor part thereof without charge for the replacement component. This warranty does not cover any labour, nor shipping or handling costs incurred. Labour warranty is the responsibility of the Installing Contractor. Any replacement of compressor or part will be warranted against manufacturing defects for the remainder of the original warranty period. Parts used in connection with normal maintenance and parts subject to normal wear and tear, such as filters and belts, are not covered by this warranty.
2. To obtain warranty service, you must notify your dealer or contractor of any manufacturing defect in the Equipment within the applicable warranty period. This warranty does not cover any labour, nor shipping or handling costs incurred. You may be responsible for shipping or handling costs incurred in delivering defective Equipment or components or parts thereof for service or replacement unless your dealer or contractor has agreed to bear such costs.
3. MITS sells this Equipment only to dealers or contractors. The dealers and contractors have sole and exclusive responsibility for the selection, application, suitability and installation of the Equipment with respect to all end users and their particular requirements. Dealers and contractors may also sell or furnish other products and equipment not supplied by or on behalf of MITS for use in conjunction with the Equipment. Accordingly, MITS makes no warranty or condition whatsoever and assumes no liability or obligation whatsoever with respect to: (a) any representation, warranty, promise or statement made by any dealer or contractor with respect to any Equipment or part thereof or the use or application thereof; b) any acts or omissions of any dealer or contractor in selecting, recommending, installing, servicing, repairing, dismantling, moving or removing any Equipment or part thereof; or (c) any products, equipment, components, accessories or materials furnished or sold to you by a dealer or contractor other than the Equipment. Your dealer or contractor may provide a separate warranty for the products and services it supplies to you in addition to the Equipment and you are advised to confirm the terms and conditions of such warranty with your dealer or installer.
4. Any replaced Equipment, compressor or part will become the property of MITS when exchanged for its replacement. MITS reserves the right of inspection or refurbishing of its equipment at its discretion.
5. Proof of the original date of installation of the Equipment must be presented in order to establish the effective date of this warranty. Otherwise, the effective date will be deemed to be the date of purchase from MITS. Register warranty at <https://www.mitsair.com/warranty-registration/>
6. This warranty applies only: (a) while the Equipment remains at the site of original installation (except for Equipment designed for portable use); (b) to Equipment installed in Canada; and (c) if the Equipment is installed, maintained and operated in accordance with the manufacturer's written instructions accompanying the Equipment and in compliance with all applicable laws, regulations, codes and bylaws. This warranty does not cover damage caused by: (a) accident, abuse, negligence or misuse; (b) operation of the Equipment in a corrosive atmosphere containing chlorine, fluorine or any other damaging chemicals; (c) improper matching or combination of other products, equipment, parts accessories or components with the Equipment; (d) modification or alteration of the Equipment; (e) repair or service by unqualified or unauthorized persons; (f) failure to install or operate the Equipment or to provide proper maintenance or service according to the manufacturer's instructions; or (g) improper application or use of the Equipment; lightning, fluctuations in electrical current; or (f) Acts of God, acts of war both declared and undeclared, acts of terrorism or use of the equipment in any unlawful application.
7. THE FOREGOING CONSTITUTES THE SOLE AND EXCLUSIVE REMEDY AND EXCLUSIVE LIABILITY AND OBLIGATION OF MITS IN CONNECTION WITH THE EQUIPMENT. THIS WARRANTY IS IN SUBSTITUTION FOR AND EXCLUDES ALL OTHER WARRANTIES AND CONDITIONS, EXPRESS OR IMPLIED, INCLUDING THE WARRANTIES AND CONDITIONS OF MERCHANTABILITY AND FITNESS FOR ANY INTENDED OR PARTICULAR PURPOSE. UNDER NO CIRCUMSTANCES WILL MITS BE LIABLE TO THE PURCHASER OF THE EQUIPMENT OR ANY OTHER PERSON FOR ANY INCIDENTAL, SPECIAL OR CONSEQUENTIAL DAMAGE OR LOSS, WHETHER ARISING OUT OF BREACH OF CONTRACT, BREACH OF WARRANTY OR TORT, AND WHETHER OR NOT MITS KNEW OR OUGHT TO HAVE KNOWN OF THE POSSIBILITY OF SUCH DAMAGE OR LOSS.
8. This warranty gives you specific legal rights, and you may have other rights which may vary from Province to Province within Canada. In the event that portions of this warranty may be struck down in your jurisdiction, this does not render the remaining portions of this warranty to be void.
9. This warranty applies only to Equipment sold in Canada by MITS and installed and used in Canada. This warranty is not transferable.
10. Register warranty at <https://www.mitsair.com/warranty-registration/>

Subject to change without notice

Distributed by:



Barrie Branch

681 Dunlop Street W, Barrie, ON L4N 9W9
1 (800) 688-1673 • barrie@mitsair.com

Head Office: Mississauga

1608 Bonhill Road, Mississauga, ON L5T 1C7
1 (800) 567-2221 • info@mitsair.com

London / Windsor Branch

90 Towerline Place, London, ON N6E 2T1
1 (519) 914-9000 • london@mitsair.com