

# BlueDiamond®

condensate removal pumps

## MicroBlue®

With no additional silencing accessories required, not only is the MicroBlue® a silent running pump but it can also be mounted in any orientation whilst operating both wet and dry continuously. The MicroBlue® is a dual voltage pump which uses proven thermistor level sensing technology to remove the risk of stuck or sunken float switches.

New GyRok™ Technology



Ducting Kit (X85-507)

### Performance

17dba

Max flow	Max head	Max suction lift
1.3 Gallons/hour	16 feet	6 feet

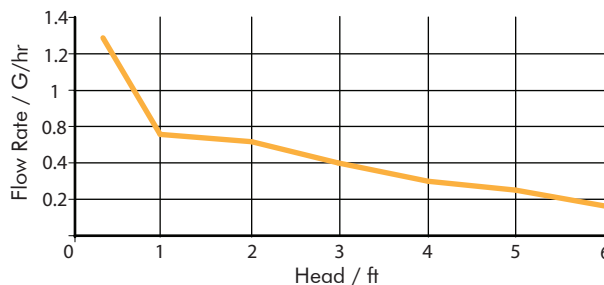

### Sensing Options

MicroBlue® pump available with:

Reservoir sensor	Ducting Kit
X85-003 (HLA PACK)	X85-507 (HLA PACK)

### Dimensions (mm)

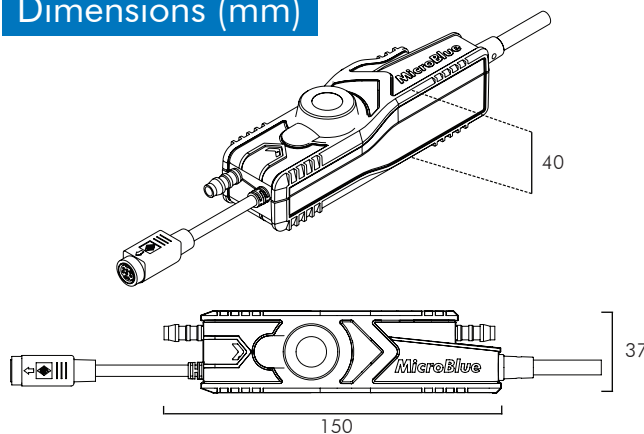

### Installation Options

The MicroBlue® can be mounted in any orientation up to 6ft away from the air conditioning unit.

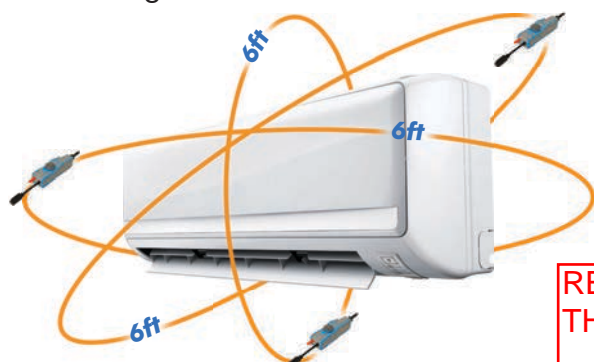

RECOMMENDED LOCATION IS IN THE DRAIN PAN



GyRok™ Technology



Indicator



DIN plug



3 year warranty